

Reaction to floor impact noise in multi-storey residential buildings: The
effects of acoustic and non-acoustic factors

Sang Hee Park and Pyoung Jik Lee

Acoustics Research Unit, School of Architecture, University of Liverpool, Liverpool, UK

Running title: Reaction to floor impact noise

Corresponding author:

Pyoung Jik Lee, Acoustics Research Unit, School of Architecture, University of Liverpool,
Liverpool, L69 7ZN, UK.

Email: P.J.Lee@liverpool.ac.uk

- Slab thickness did not correlate with the subjective responses.
- Noise sensitivity had significant associations with the responses.
- House ownership had significant associations with the responses.
- Empathy moderated annoyance and anger responses.
- Residents in noisy outdoor ambient reported higher noise sensitivity.

Abstract

This study aimed to investigate whether different acoustic and non-acoustic factors have effects on the subjective responses to floor impact noise made by upstairs neighbours in multi-story residential buildings. An on-site evaluation was conducted in four different apartment complexes with 100 residents from each site ($N = 400$). All the buildings had a box-frame-type structure with reinforced concrete slab floors with different thicknesses; two sites used 150 mm slabs, another used 180 mm, and the last used 210 mm slabs. The participants responded to a questionnaire which measured annoyance, anger, and empathy as their subjective responses to floor impact noise. The questionnaire also asked about socio-demographic, personal, and situational variables. Outdoor noise measurements were carried out for 24 hours on the top of the buildings at each site in order to assess any masking effect of ambient noise on the subjective responses to the indoor noise. Results showed that the subjective responses were significantly affected by noise sensitivity and house ownership. Those who had higher noise sensitivity or those who were house owners reported higher annoyance and anger towards floor impact noise. Outdoor noise did not have any masking effect on the responses but those who lived in higher ambient noise levels reported higher annoyance and anger to the indoor noise. The subjective responses were not solely understood by slab thickness; however, slab thickness contributed to predicting the subjective responses with other variables. These findings imply that it is limited to fully explain the subjective responses to floor impact noise without other acoustic and non-acoustic factors such as noise sensitivity.

1 Introduction

Residents in multi-story residential buildings are easily exposed to floor impact noise coming from upstairs. In particular, floor impact noise has been suggested as the most annoying noise source in this type of housing in South Korea [1-3]. Statistics Korea [4] reported that such type of housing accounted for over 60.1% of the whole housing units available in 2016. It means that there is a large segment of the population in South Korea who are likely to be exposed to floor impact noise. The proportion of multi-story residential buildings has been growing all over the world [5, 6]. According to the recent report of the Floor Noise Management Centre in Korea, there were 123,969 complaints about both structure-borne and air-borne noise from neighbours since 2012 [7]. In addition, 82.6% of the complaints were due to floor impact noise, which includes 70.9% of footstep noise [7]. This report supports the previous findings that footstep noise such as walking, running, and jumping evoked the most annoyance to the residents [1, 3]. The report also stated that the majority of noise complainants resulted in disputes and conflicts with their neighbours [7]. Furthermore, four murder cases between neighbours were recorded in 2013 which were retaliatory crimes caused by an emotional reaction to noise issues [8].

A number of studies have attempted to investigate the subjective responses to floor impact noise in laboratory settings. They have found that higher A-weighted maximum sound pressure levels (L_{Amax}) led to greater self-reported annoyance responses [9, 10]. Lee et al. [9] examined the subjective responses to noise stimuli induced by an impact ball and found that sound quality ratings (e.g. Zwicker's Loudness Level, LL_z) and instrumental metrics (e.g. L_{Amax}) had significant correlations with self-reported annoyance ratings. In particular, L_{Amax} was suggested as a practical descriptor of the auditory sensation of the impact ball noise [9]. Recent studies also supported the strong relationship between the L_{Amax} of impact sounds and self-reported

annoyance [11, 12]. In addition, exposure to floor impact noise has been found to influence physiological changes such as heart rate and respiration rate [13, 14].

Accordingly, there have been a lot of attempts to reduce floor impact noise levels by developing acoustic materials and floor structures. For instance, floating floors have been widely used to decrease structure-borne and air-borne sound transmission by isolating the upper parts of the floors from the structure [15]. Although floating floors were effective at reducing lightweight impact noise, little change was found in relation to heavyweight impact noise levels [16]. Another way to reduce both heavyweight and lightweight noise levels is to increase slab thickness. There are previous studies which have reported the notable relationship between slab thickness and floor impact noise levels [17-19]. More precisely, heavyweight impact sound pressure levels decreased by 2 dB when the slab thickness increased by 30 mm [19]. A more recent study found that 20 mm increments in concrete slab thickness led to a decrease in impact sound pressure levels between 3 and 7 dB [17]. Yeon et al. [20] measured sound pressure levels of standard and real impact sounds in 30 apartments with different slab thicknesses (i.e. 135, 150, 180, and 210 mm). They confirmed the previous suggestions by providing significant negative correlations between slab thickness and sound pressure levels [20]. In particular, slab thickness had the biggest negative correlation with impact noise levels of a tapping machine while it showed the smallest correlation with noise levels of real impact sources such as an adult's walking [20]. Based on such research findings, the Korean Government has strengthened domestic regulations since 2005 by increasing the concrete slab thicknesses to 210 mm [21, 22]. Therefore, it was expected that the increase in slab thickness would resolve the noise complaints due to floor impact noise in recently built apartments.

On the other hand, data from a recent field measurement are rather controversial because it showed there was no general relationship between slab thickness and floor impact noise

levels [23]. Park et al. [23] conducted noise measurements for 24 hours in 26 residential buildings while the occupants vacated their houses. The sites were classified into two groups based on the slab thickness: the first group were those with slab thicknesses of 135 and 150 mm and the second group were those with slab thicknesses of 180 and 210 mm. It was found that the L_{Amax} of the first group was slightly higher than that of the second group, but the difference was not statistically significant. However, Park et al. [23] did not assess the subjective responses to floor impact noise; therefore, it is necessary to investigate the relationship between slab thickness and the subjective responses to the noise. Emotional responses (e.g. anger) to the noise would be worth being assessed because annoyance cannot be fully predicted by noise level itself [24] and in order to test a previous suggestion of the correlations between annoyance and different emotions [25].

This study, therefore, sets out to assess the effect of slab thickness on the subjective responses to floor impact noise by conducting questionnaire surveys. It was hypothesised that thicker slabs would lead to less negative reactions to floor impact noise. It was also hypothesised that there would be acoustic and non-acoustic factors affecting the perception of floor impact noise. In order to validate this hypothesis, several non-acoustic factors were introduced such as noise sensitivity and house ownership. Field surveys were performed in four apartment complexes which used different slab thicknesses. Participants were asked to rate their annoyance, anger, and empathy as to the floor impact noise heard in their homes. In addition, it was assessed if the subjective responses were affected by socio-demographic, personal, and situational variables. During the surveys, outdoor noise levels were measured to test if ambient noise masks the subjective responses to floor impact noise [26].

2 Methods

2.1 Sites

As listed in Table 1, four apartment complexes in the Gyeonggi province of South Korea took part in the study. The oldest one was built in 1994 (Site A) and the newest site was built in 2014 (Site D). The biggest site had 1,827 houses (Site A), whereas the smallest one had 262 houses (Site C). Slab thickness of the apartments varied from 150 to 210 mm: 150 mm slabs were used in Sites A and B, 180 mm in Site D, and 210 mm in Site C. Floor area also varied from 52 (in Site D) to 157 m² (in Site C). The average price per square metre of residences in Site A was the highest but the properties at Site C were the most expensive due to the bigger floor area. Site D was a type of public rental housing which is owned by the government and offered with a long-term rent plan. Thus, there was no information about the average price per square metre for Site D. The present study aimed to minimise the variations of factors affecting floor impact noise levels. First, all the buildings had the same structure which is a box-frame-type reinforced concrete construction. Secondly, the buildings with similar floor structures were chosen. As shown in Figure 1, the floors consisted of the reinforced concrete slab, resilient material, lightweight concrete, and finishing mortar. All the resilient materials were Expanded Polystyrene (EPS) and thicknesses of the materials varied from 20 to 30 mm.

Table 1

Figure 1

As shown in Figure 2, there were traffic roads near all of the sites. Sites A and B were nearby roads with three or more lanes, while Sites C and D were close to roads with a smaller number of (e.g. one or two) lanes. In addition, Sites A, B, and C were located in the vicinity of railways so they were exposed to additional railway noise. Outdoor noise levels were measured

for 24 hours using sound level metres (SVAN 943, Svantek) positioned 1.2 m above the ground mounted on tripods. All sound level metres were placed on top of the buildings which are marked in grey in Figure 2. Outdoor noise levels of Site C could only be measured at three buildings due to the apartment complex's regulations. At the other sites, outdoor noise levels were measured at five buildings each. From the 24-hour noise recordings, L_{DEN} (Day-Evening-Night noise levels) were calculated. A penalty of 5 dB was added from 19:00 to 22:00, and a penalty of 10 dB was added from 22:00 to 07:00 to derive L_{DEN} .

Figure 2

2.2 Questionnaire

Participants were asked to complete the questionnaire during face-to-face interviews in separated rooms within the management office of each site. In the present study, the questionnaire was divided into three main sections. The first section dealt with the participants' responses to floor impact noise in their homes. First, the level of annoyance caused by floor impact noise was assessed. Noise annoyance was rated using an 11-point scale (0 = 'not at all' and 10 = 'extremely') as recommended by the ICBEN team [27] and the ISO 15666 standard [28]. Participants were provided with the following instruction: "Thinking about the last 12 months or so, when you are in your home, how much does floor impact noise annoy you?" Second, the emotional responses to floor impact noise, particularly anger and empathy, were assessed using 10 lexicons provided in the recent study [25]. The five lexicons used for anger were 'unhappy', 'detestable', 'can't understand', 'get enraged', and 'ridiculous', while the five lexicons about empathy were 'bearable', 'just being patient', 'tolerable', 'no reason for discomfort', and 'think of it as usual'. The participants were asked to rate their emotions on a

7-point scale (0 = *'not at all'* and 6 = *'extremely'*) according to the following instruction: "Please rate the extent to which each lexicon is appropriate for expressing your emotions towards the floor impact noise you have heard for the last 12 months." For those who had lived in their current houses for less than 12 months, they were asked to think about the period that they had lived in the current house. The second section of the questionnaire was to measure situational variables [29] in terms of the major noise source, time of the noise exposure, and any child(ren) upstairs; these were regarded as acoustic factors because they were the details of the floor impact noise which the participants had been mainly exposed to. The participants were asked to choose one of six noise sources; the six sources were adopted from the previous report on the most common noise sources in real apartment buildings [23]. They were two heavyweight impact noise sources (i.e. children's footsteps and adults' footsteps) and four lightweight impact noise sources (i.e. furniture scraping, items dropping, door banging, and plumbing system). Five options were given for the participants to choose the major time of the noise exposure: 06:00 ~ 09:00, 09:00 ~ 12:00, 12:00 ~ 18:00, 18:00 ~ 20:00, and 20:00 ~ 06:00. The questionnaire also asked whether there were any children living upstairs since the footstep noise of children has been known to be the dominant noise source in apartment buildings [15]. The third section of the questionnaire concerned non-acoustical factors affecting the subjective responses to noise. Non-acoustical factors were classified into personal and socio-demographic variables [29]. As a personal variable, noise sensitivity was measured using Weinstein's scale [30].

2.3 Participants

One hundred residents from each site took part in the study. Information about the participants is listed in Table 2. The age of the participants ranged from 20 to 60 years old and

the mean age of the whole participants was 42.9 years old (std. deviation = 10.5). Male and female participants were recruited almost evenly from each site. More than half of the participants from Sites A and C reported that they did not live with a child. More than half of participants from Sites B and C reported that there were one or more children living upstairs. Most of the participants' education levels were at university/college level. The majority of the participants were employed and most of them were employed full-time. Length of residency ranged from 2 months to 277 months (23 years and 1 month), partially correlating with the age of the building. Most of the participants from Sites A, B, and C reported that they owned their houses, whereas all of the participants from Site D rented their houses from the government.

Table 2

2.4 Data analysis

Statistical analyses were conducted using SPSS for Windows (version 22.0, SPSS Inc. Chicago, IL). Bivariate correlations were tested in order to examine correlations between the variables. The significance of differences between two correlation coefficients was tested using Fisher's *r*-to-*z* transformation (an online computation available at <http://vassarstats.net/index.html>). In the case of two correlation coefficients obtained from the same sample which shared one variable in common, each correlation coefficient was converted into *z*-score using Fisher's *r*-to-*z* transformation and the asymptotic covariance of the estimates was calculated by Steiger's equations [31]. Independent samples *t*-tests and one-way analyses of variance (one-way ANOVA) were performed to compare the responses between groups. In addition, multiple linear regression analyses were conducted to investigate significant variables

influencing the responses. In the present study, p values of less than 5% ($p < 0.05$) were considered as statistically significant.

3 Results

Figure 3 illustrates the subjective responses (i.e. annoyance, anger, and empathy) to floor impact noise across the four sites. The annoyance rating of Site A was the highest (mean = 4.5; std. deviation = 3.4), whereas Site D showed the lowest rating (mean = 3.4; std. deviation = 2.6). Only the annoyance ratings between Sites A and D were significantly different ($p < 0.05$), indicating that the residents of Site A experienced a greater level of noise annoyance due to floor impact noise than those in Site D. Similarly, Site A and Site D showed the highest (mean = 2.6; std. deviation = 1.3) and lowest (mean = 1.7; std. deviation = 1.1) anger ratings respectively and they were significantly different ($p < 0.01$). Significant differences were also found between Sites A and B, as well as Sites C and D ($p < 0.01$ for both). In empathy ratings, the rating of Site B was the highest, followed by Sites D, A, and C. It was found that most of the empathy ratings were significantly different from one another ($p < 0.01$ for all).

Figure 3

3.1 The effects of acoustic factors

The annoyance, anger, and empathy ratings caused by floor impact noise across different slab thicknesses (i.e. 150, 180, and 210 mm) are plotted in Figure 4. Sites A and B used the same slab thickness (i.e. 150 mm) so the results of the two sites were merged together for this comparison. The highest annoyance rating was observed from the 150 mm slabs (mean = 4.3; std. deviation = 3.0). However, contrary to expectations, the annoyance rating of the 180 mm

slabs was lower than the 210 mm slabs. In addition, the annoyance ratings of different slab thicknesses were not statistically different. It was hypothesised that the residents living in buildings with thicker slabs would report lower anger and higher empathy than others with thinner slabs. However, the lowest anger (mean = 1.7; std. deviation = 1.1) and the highest empathy (mean = 3.6; std. deviation = 0.7) were found in the 180 mm slabs (i.e. Site D). The participants from the site with 210 mm slabs (i.e. Site C) even reported the highest anger (mean = 2.5; std. deviation = 1.2) and lowest empathy (mean = 2.9; std. deviation = 0.6).

Figure 4

As listed in Table 3(a), the most frequent noise source across the sites was children's footstep noise, followed by adults' footstep noise and items dropping. In particular, 53% of the participants from Site B reported children's footstep noise as being the major noise source. In addition, it was found that heavyweight impact sources (children and adults' footstep noises) were more dominant than lightweight impact sources. To examine the influence of dominant noise sources on the subjective responses, the two groups who reported the heavyweight and lightweight sources as the dominant noise source were compared. It was found that there was no significant difference between the groups. Table 3(b) also shows the times of the day when the floor impact noise was dominantly heard. It was found that night-time (between 20:00 and 06:00) was the most dominant time for noise exposure, accounting for 54.8% across the sites. The subjective ratings were also compared between the three time periods of noise exposure (20:00 ~ 06:00, 06:00 ~ 09:00, and 09:00 ~ 20:00), but a significant difference was not found.

Table 3

3.2 The effects of non-acoustic factors

In order to investigate the effect of noise sensitivity on the subjective responses, the participants were divided into two groups concerning their noise-sensitivity scores. The mean and median noise-sensitivity scores were 79.4 and 79.0 respectively. The median value was used as a cut-off point to classify the participants. The participants whose noise-sensitivity scores were ≤ 79 were grouped as the low noise-sensitivity group ($N = 204$) and those with noise-sensitivity scores above 79 were grouped as the high noise-sensitivity group ($N = 196$). The low noise-sensitivity group's mean noise-sensitivity score was 68.7 (std. deviation = 7.3), while that of the high noise-sensitivity group was 90.6 (std. deviation = 7.7). The responses were significantly different between the noise-sensitivity groups across each of the sites (Figure 5). These results indicate that the noise sensitive participants perceived greater annoyance and anger while expressing less empathy compared to those who were less sensitive to noise. The difference in annoyance ratings between the two groups was much greater than the differences in the anger and empathy ratings. However, the differences between the groups were statistically significant for all of the subjective responses.

Figure 5

House ownership is a long-term investment, so it is quite clear that investors are interested in maintaining and increasing the value of their investment [32]. The residents might have different attitudes to the noise sources and events affecting the value of the house. Thus, in the present study, it was hypothesised that house ownership might affect the subjective responses to floor impact noise. In order to examine this assumption, the participants were classified into house owners ($N = 271$) and renters ($N = 196$). As presented in Figure 6, house owners showed

greater annoyance and anger ratings than renters, whereas owners demonstrated lower empathy. The differences between house owners and renters were statistically significant across all of the subjective responses. These differences imply that owners perceive floor impact noise more negatively than renters. These also can be understood with respect to the socio-demographic characteristics because the owners were older, had higher income and education levels, and longer residency than renters. Moreover, all of the residents in Site D were classified as renters, so there could be other variables moderating this result. For example, length of residency. Site D was the newest site and thereby the mean length of residency was also the shortest among the four sites.

Figure 6

Furthermore, annoyance, anger, and empathy ratings were compared across the socio-demographic variables (gender, age group, and child(ren) at home). Although females reported higher annoyance and anger ratings (4.1 and 2.3, respectively) than males (4.0 and 2.1, respectively), there was no significant difference between males and females for all of the subjective ratings. It was also found that the participants in their 20s and 60s showed significant differences in their annoyance and anger ratings. The mean annoyance and anger ratings for those in their 60s were 3.1 (std. deviation = 2.6) and 1.8 (std. deviation = 1.0), respectively, while those for the 20s group was 4.6 (std. deviation = 2.7) and 2.5 (std. deviation = 1.2), respectively. The mean empathy rating for the 60s was 3.6 (std. deviation = 0.7), which was significantly higher than that of the 50s (mean = 3.1; std. deviation = 0.8). Moreover, there was no difference between the participants who had one or more children at home and those who did not have any children. Those who had children reported a slightly higher empathy (mean =

3.4; std. deviation = 0.8) than those who did not (mean = 3.3; std. deviation = 0.8), but the difference was not significant.

Table 4 shows the correlation coefficients between the subjective ratings and non-acoustic factors. Noise sensitivity had a strong correlation with the annoyance, anger, and empathy ratings for all sites; it was positively correlated with annoyance and anger while it had a negative correlation with empathy. Fisher's r-to-z transformation [31] was used to test if the correlations between noise sensitivity and subjective ratings were significantly different. It was revealed that noise sensitivity had significantly stronger correlations with anger than annoyance, except in Site D. There was no significantly stronger coefficient between noise sensitivity and annoyance across the sites. However, the smallest correlation coefficients of noise sensitivity with anger and empathy were found in Site D ($r = .82$ and $-.72$, respectively) and they were found to be significantly different from the other coefficients at the other sites.

Table 4

3.3 The effects of multiple factors

A number of studies have established relationships between annoyance and exposure level of transportation noise [33, 34]. Several authors also extended the relationship by adding noise sensitivity and socio-demographic variables [24, 35, 36]. Similarly, simple regression models were developed to examine the influence of noise sensitivity and socio-demographic variables on the subjective ratings. However, contrary to environmental noise, it is not practical to measure or predict indoor noise level. Therefore, slab thickness was introduced as an independent variable assuming that indoor noise level decreases as slab thickness increases. In addition to the slab thickness, tested variables were building age, the participants' age,

education level, occupation, income, length of residency, and floor area. All of the variables were translated into a 0 ~ 100 scale calculated based on the equation used in previous multiple regression analyses [37]. The multiple regression models are summarised in Table 5. There was no significant bivariate correlation between the slab thickness and annoyance, indicating that the slab thickness itself does not have a strong relationship with annoyance. On the other hand, the slab thickness had a small but significant regression coefficient in the multiple regression model of annoyance with other independent variables. Specifically, the regression model included slab thickness, building age, and noise sensitivity as the independent variables for predicting annoyance. Given that the standardised regression coefficients of noise sensitivity ($\beta = .84$) were considerably greater than the others' (β s = .10 and .22 for slab thickness and building age, respectively), it could be assumed that noise sensitivity played the more significant role than others in the prediction of annoyance.

Table 5

4 Discussion

4.1 Slab thickness

This study did not conduct indoor noise measurements because it was not feasible to ask all 400 participants to vacate their houses for the measurements or to place sound level metres in 400 houses. Instead, this study focused on slab thickness, which has been found to be associated with sound insulation performance [17-19]. We examined whether slab thickness affected the subjective responses to floor impact noise. It was revealed that there was not a strong trend between different slab thicknesses and the subjective ratings. The sites with the thinnest slabs (i.e. 150 mm) showed the highest annoyance rating, followed by those of 210

and 180 mm, respectively. In addition, the residents who lived in buildings with 210 mm slabs expressed the highest anger, while the empathy rating of the residents from the site with 180 mm slabs was greater than those with 150 mm slabs. These findings are not consistent with the previous suggestions made in laboratory studies, in that a thicker slab thickness leads to lower noise levels [18, 19], and that the lower the noise levels result in lower annoyance ratings [13, 14]. Instead, this study yielded further evidence supporting the findings of the prior field research [20, 23]. As reported earlier [23], an increase in slab thickness cannot guarantee better acoustic comfort with lower noise levels or fewer noise events in real life since the occurrence of neighbouring noise including floor impact noise is mainly affected by the neighbour's behaviours and activities. Yeon et al. [20] also reported that slab thickness had a minimal correlation with noise levels from a real impact source. Moreover, the results from the multiple linear regression analyses (Table 5) confirmed that the subjective responses to floor impact noise can be explained not just by the acoustic factors such as sound insulation performance from the slab thickness, but also by different non-acoustic factors [38]. Furthermore, impact sound insulation performance is affected by various factors such as dynamic properties of resilient isolator and floor areas. In the present study, the resilient isolators of the Sites C and D had much lower dynamic stiffness compared to those of the Sites A and B which were built before the introduction of domestic guideline of sound insulation performance. In addition, previous studies (e.g. Lee [39]) reported that the heavyweight impact sound insulation performances varied across floor areas for apartments with same floor structure and resilient material. Therefore, some particular features of each site and those of residents need to be compared to one another in order to seek out any potential factors affecting the subjective ratings. Moreover, experimental and numerical approaches [e.g., 40] could be used to predict

the heavyweight impact sound insulation performances and to examine the links between objective characteristics and subjective responses.

4.2 Outdoor noise levels

Residents are exposed to outdoor transportation noise (e.g. road traffic noise) as well as indoor building noise (e.g. floor impact noise) in their homes. Contrary to floor impact noise, road traffic noise is stationary and heard continuously; thus, it could be regarded as ambient noise. Previously, Jeon et al. [41] demonstrated that the annoyance ratings of non-stationary noise in combination with road traffic noise were related to different noise levels. Based on this finding, this study hypothesised that the perception of floor impact noise might be affected by outdoor noise levels because of the masking effects [26]. Questionnaire responses from 18 buildings where outdoor noise levels were measured ($N = 244$) were used in order to examine the influence of ambient noise levels on the perception of floor impact noise. Firstly, it was found that the relationship between outdoor noise level (L_{DEN}) and the subjective responses to floor impact noise was not statistically significant. This indicates that the perception of indoor noise is independent of the ambient noise level. Secondly, the outdoor noise levels were categorised into three groups: 1) < 50 dB, 2) $50 \sim 60$ dB, and 3) > 60 dB. It was expected that loud ambient noise might reduce the annoyance and anger ratings of floor impact noise by masking intermittent and impulsive noise. However, as shown in Figure 7, the residents who were exposed to outdoor noise levels above 60 dB expressed the highest annoyance and anger ratings with the lowest empathy rating. The annoyance and anger ratings from the buildings with the loudest ambient noise (> 60 dB) were significantly greater than other groups ($p < 0.01$ for both). These results might be because the residents who live in buildings with higher ambient noise levels (> 60 dB) might perceive the noise more negatively than others, and be

more sensitive to noise. The mean noise-sensitivity score of this group (> 60 dB) was 81.8, which was much greater than the other groups. Therefore, additional attention would be required to design the floor structure of buildings located in noisy areas. However, in the present study, the measured outdoor noise levels of each building were used rather than the noise levels of each unit. Future research could predict the noise levels of each unit or story using a computer simulation to further test the masking impact of outdoor noise on the perceptions of indoor noise.

Figure 7

4.3 Financial investment

One of the unexpected findings in this study was that the participants from Site C, which used the thickest slabs (i.e. 210 mm), reported higher negative responses (annoyance and anger) compared to those from Sites B and D with thinner slabs (150 and 180 mm, respectively). This result implies that other socio-demographic variables might have affected the subjective responses. It has been known that house owners are concerned about local noise and expect future improvement more than renters. This is mainly because house owners financially invest more into the property than renters [42]. In this study, most of the participants from Sites A, B, and C were house owners, whereas all of the participants from Site D were renters. As has already been shown in Figure 6, house owners reported significantly higher annoyance and anger than renters. Given that most of the renters in this study were from one site (Site D), there is still a remaining question whether the renters in this study could actually be representative. Thus, further investigation is needed into this factor by recruiting the samples with wider ranges of factors. In addition, the floor area was the biggest in Site C so the residents in Sites C must

have a greater financial investment than those in the other sites. Therefore, residents who paid more for the properties expect better acoustic comfort, more concern, and were more annoyed by noise in their dwellings [36, 43]. Since this study did not ask the participants how much money they invested into their properties (e.g. house price and mortgage), future research could examine the impacts of the financial investment on the subjective responses. Given that this study found that noise sensitivity had significant impacts on the responses, future research could also assess how financial investment associates with noise sensitivity.

4.4 Empathy

Similar to the previous studies [1-3], children's footstep noise was the dominant noise source in the present study. Those who have children are more likely to be empathetic to children's noise from upstairs [38]. Thus, it was assumed that those who were living with children would report lower annoyance and anger ratings due to empathy toward their neighbours. Confirming the study's hypothesis, the highest empathy ratings were found at Sites B and D, where the number of participants who lived with one or more children was the highest. This result suggests that living with one or more children might lead to greater empathy. This finding is also in agreement with what the previous qualitative study reported; residents who had children expressed more empathy than those who had no children, and consequently, people with empathy tended to make fewer noise complaints [38]. Assuming a lack of empathy may contribute to higher annoyance and anger, the participants were divided into a low empathy group ($N = 203$) and high empathy group ($N = 197$). The groups were divided using the median value of the empathy rating (3.33) as a cut-off point. Figure 8 compares the annoyance and anger ratings between the low and high empathy groups. It was found that the high empathy group reported significantly lower annoyance and anger ratings than the low

empathy group. It indicates that having empathy towards upstairs neighbours would decrease one's negative perception (e.g. annoyance and anger) regarding neighbour noise. As discussed in the former section, the experience of living with children may help one to be understanding and empathetic towards neighbours particularly those with children.

Figure 8

4.5 General discussion

As plotted in Figure 3, Site D with slab thickness of 180 mm showed the lower annoyance and anger rating than other sites with thicker or thinner slab thicknesses. This result can be explained by considering other factors. First, Site D was most recently built among the sites so it is arguable that new buildings of Site D might have influenced the decrease of the annoyance and anger ratings. Table 5 also showed that the standardised regression coefficients of the building age on the annoyance and anger the ratings were positive (β s = .22 and .45, respectively), indicating that older buildings led to greater annoyance and anger ratings. Second, all the residents at Site D were renters, whereas other sites had a mixture of owners and renters. Significant differences in subjective responses were found between house owners and renters (Figure 6); thus, it could be argued that renters may perceive less annoyance or anger against floor impact noise than owners. However, as discussed previously, there are still challenges that need further investigations to validate the relationship between house ownership and subjective responses. Third, Site D was the only site without railway noise nearby and it had the lowest outdoor noise level. The result showed that those who were exposed to the higher outdoor noise levels (> 60 dB) had higher mean noise-sensitivity score than the other groups. Given that noise sensitivity had the strongest impacts on the prediction of all the subjective

responses in the multiple regression models, the lowest annoyance and anger ratings of Site D could be explained by using the shortest building age, house ownership as being renters, low outdoor noise level, and low noise sensitivity.

As shown in Figure 5, noise sensitivity clearly affected the subjective ratings. This finding is in line with previous studies which have found there to be a significant influence from noise sensitivity on annoyance and emotional ratings [25, 44, 45]. This study also revealed that residents who were from buildings with higher outdoor noise levels reported higher noise sensitivity as well as more of a negative response to floor impact noise. In addition to noise sensitivity, one's attitude towards one's neighbours has been suggested to be another variable affecting the subjective responses to floor impact noise because upstairs neighbours are the main source of the noise [38]. However, it has been discussed that the questionnaire assessing the attitude toward the upstairs neighbours needs to be further developed and improved in order to adequately examine its impact on the subjective responses [25, 44]. This study makes the suggestion that the questionnaire can include items about social cohesion or a sense of community. Existing instruments used to measure the sense of community [46, 47] would provide a further understanding of how the attitudinal factors perceived in relation to one's neighbours need to be measured.

Previous field studies on indoor noise mainly focused on sound insulation performance [11, 12, 17, 20, 48]; thus, they either did not concern real noise sources [11, 12] or did not evaluate the subjective responses to the noise [17, 20, 48]. Ljunggren and his colleagues measured the sound insulation performances of floors using standard sources (e.g. tapping machine and impact ball) in different types of buildings [11, 12]. They also collected the occupants' subjective responses to the noise but did not measure real noise sources such as human footsteps coming from upstairs. On the other hand, the present study paid attention to

the residents' subjective response to real indoor noises. Moreover, this study mainly focused on the slab thickness in order to test previous findings [17-19, 48]. This study has revealed that increased slab thickness cannot guarantee better acoustic comfort because all of the residents are exposed to different levels of noise due to their upstairs neighbours' different activities and behaviours [23]. Future research may consider different characteristics of the noise source (e.g. upstairs neighbours and their activities) and different characteristics of the house and construction (e.g. floor area and resilient materials) when it comes to the examination of floor impact noise levels.

5 Conclusions

The present study aimed to fulfil an existing need, as there was a lack of field research on subjective responses to floor impact noise (e.g. footstep noise induced by upstairs neighbours). A questionnaire was designed to evaluate the residents' subjective responses to the noise and other factors which were assumed to influence the responses. First, self-rated annoyance and two emotional responses (anger and empathy) caused by floor impact noise were assessed. Second, variables on situational (major noise source), personal (noise sensitivity), and socio-demographic (income and length of residency) characteristics were measured. Four sites with different slab thicknesses were recruited for the on-site evaluations. One hundred residents from each site took part in the study, so a total of 400 responses were collected and analysed. Along with the questionnaire, outdoor noise levels were measured at each site in order to investigate the effect of ambient noise levels on the subjective responses to the indoor noise. From the results, the implication was made that the increase in slab thickness was not enough to resolve the negative responses or conflicts between neighbours regarding floor impact noise. However, as observed in the multiple regressions analysis, it is still necessary to consider slab

thickness as one of several factors for predicting how residents respond to indoor noise. Given that sound insulation performance is affected by several factors (e.g., dynamic property of resilient isolator and floor area), the study suggested further research on various acoustic features of residences in order to understand occupants' responses to indoor noise. Noise sensitivity significantly associated with all of the subjective responses, indicating that noise-sensitive residents reported greater annoyance and anger ratings. The house owners reported higher annoyance and anger; however, this finding should be validated with more samples of the renters by focusing on the effects of residents' financial investment on subjective responses. It was also found that residents living in buildings with higher outdoor noise levels reported higher noise sensitivity, annoyance, and anger. This implies that those who were exposed to higher ambient noise levels tended to have higher noise sensitivity, which consequently led them to perceive higher annoyance and anger towards the indoor noise. Since the study used the outdoor noise measurements collected from the top of some buildings, there is a need for additional investigation to predict the noise levels of each unit to test the masking effect of outdoor noise more in-depth.

Acknowledgement

This research was supported by a grant [18RERP-B082204-05] from Residential Environment Research Program funded by Ministry of Land, Infrastructure and Transport of Korean Government.

Figure captions

- Figure 1. Floor structure of each site. The floors of all sites contained reinforced concrete slab, resilient isolator, lightweight concrete, and cement mortar with different thicknesses and they were finished by wooden floorings.
- Figure 2. Site plans of four apartment complexes. Grey boxes indicate the buildings where the outdoor noise levels were measured.
- Figure 3. Mean annoyance, anger, and empathy ratings across Sites A, B, C, and D with error bars indicating standard errors (* $p < 0.05$, ** $p < 0.01$).
- Figure 4. Mean annoyance, anger, and empathy ratings across different slab thicknesses (150, 180, and 210 mm) with error bars indicating standard errors (* $p < 0.05$, ** $p < 0.01$).
- Figure 5. Mean annoyance, anger, and empathy ratings across the low and high noise-sensitivity groups (* $p < 0.05$, ** $p < 0.01$). Grey and white bars represent the responses of the whole sites ($N = 400$) and each site ($n = 100$), respectively.
- Figure 6. Mean annoyance, anger, and empathy ratings across the house owners and renters with error bars indicating standard errors (* $p < 0.05$, ** $p < 0.01$).
- Figure 7. Mean annoyance, anger, and empathy ratings across the outdoor noise levels (L_{DEN}) with error bars indicating standard errors (* $p < 0.05$, ** $p < 0.01$).
- Figure 8. Mean annoyance and anger ratings across the low and high empathy groups with error bars indicating standard errors (* $p < 0.05$, ** $p < 0.01$).

Table 1. Information about the selected sites.

Site No.	A	B	C	D
Construction year	1994	2002	2009	2014
Number of buildings	21	7	7	8
Number of residences	1,827	583	262	522
Number of floors	25	23	15	18
Slab thickness [mm]	150	150	210	180
Floor area [m ²]	58 ~ 85	84	107 ~ 157	52 ~ 60
Outdoor noise level: L_{DEN} [dBA]	49.8 ~ 61.7	58.9 ~ 66.1	56.6 ~ 68.8	44.3 ~ 54.5
Average price per square metre ^a	£2,533	£2,127	£2,047	·

^a converted South Korean Won (₩) to British Pound (£) with an exchange rate of 1 GBP = 1,500 KRW

Table 2. Information about the participants from each site.

		Whole	Site No.			
			A	B	C	D
Age [years]	Mean	42.9	44.3	41.6	42.5	43.4
	Std. Deviation	10.5	9.6	11.2	10.5	10.6
Gender [<i>N</i>]	Male	192	45	46	56	47
	Female	208	55	54	44	53
Child(ren) at home [<i>N</i>]	Yes	177	30	58	39	50
	No	223	70	42	61	50
Child(ren) upstairs [<i>N</i>]	Yes	218	50	61	59	48
	No	114	35	24	27	28
	Don't know	68	15	15	14	24
Education [<i>N</i>]	Middle school or lower	0	0	0	0	0
	High school	73	17	22	13	21
	University/College	293	80	65	74	74
	Postgraduate	34	3	13	13	5
Occupation [<i>N</i>]	Full-time employed	206	64	54	45	43
	Part-time employed	58	14	10	21	13
	Self-employed	28	5	5	11	7
	Student	35	6	16	9	4
	Homemaker	69	11	15	11	32
	Unemployed	3	0	0	3	0
	Other	1	0	0	0	1
Income ^a [<i>N</i>]	under £13,327	3	1	0	2	0
	£13,327 ~ £19,993	38	10	1	16	11
	£19,993 ~ £26,660	66	20	3	26	17
	£26,660 ~ £33,327	111	35	7	33	36
	£33,327 ~ £39,993	104	24	35	18	27
	more than £39,993	78	10	54	5	9
Length of residency [months]	Mean	85.4	141.1	107.6	59.2	33.7
	Std. Deviation	62.8	78.3	42.5	29.0	9.4
House ownership	Yes (owner)	271	90	94	87	0
	No (renter)	129	10	6	13	100
Noise-sensitivity score	Mean	79.4	78.7	79.6	79.3	80.3
	Std. Deviation	13.3	11.7	11.0	15.6	14.6
Noise-sensitivity group [<i>N</i>]	Low	204	57	54	46	47
	High	196	43	46	54	53

^a converted South Korean Won (₩) to British Pound (£) with an exchange rate of 1 GBP = 1,500 KRW

Table 3. Frequency percentages of major noise source and time of noise exposure.

(a) Major noise source

		Whole	Site No.			
			A	B	C	D
Heavyweight	Child	38.5	32.0	53.0	37.0	32.0
	Adult	25.0	26.0	18.0	26.0	30.0
Lightweight	Furniture	12.3	10.0	15.0	12.0	12.0
	Items	12.5	15.0	10.0	11.0	14.0
	Door	6.3	15.0	0.0	6.0	4.0
	Plumbing	5.5	2.0	4.0	8.0	8.0
Total		100.0	100.0	100.0	100.0	100.0

(b) Time of noise exposure

	Whole	Site No.			
		A	B	C	D
06:00 ~ 09:00	28.5	41.0	32.0	18.0	23.0
09:00 ~ 12:00	4.5	3.0	2.0	7.0	6.0
12:00 ~ 18:00	3.3	4.0	2.0	4.0	3.0
18:00 ~ 20:00	9.0	10.0	2.0	16.0	8.0
20:00 ~ 06:00	54.8	42.0	62.0	55.0	60.0
Total	100.0	100.0	100.0	100.0	100.0

Table 4. Correlation coefficients between the subjective ratings and the tested variables (* $p < 0.05$, ** $p < 0.01$).

		Noise sensitivity	Age	Education	Occupation	Income	Length of residency	Floor area
Annoyance	Whole	.83**	-.10*	.03	-.01	.03	.06	.03
	Site A	.88**	-.08	.04	-.14	.07	-.07	-.06
	Site B	.87**	-.17	.04	.01	.04	.05	.
	Site C	.88**	-.08	-.03	.26**	.01	-.02	.02
	Site D	.81**	-.09	.05	-.05	.05	.04	.22*
Anger	Whole	.85**	-.12*	.02	-.04	-.04	.08	.10
	Site A	.94**	-.13	.00	-.13	.02	-.13	-.06
	Site B	.91**	-.18	.00	-.01	.02	.02	.
	Site C	.94**	-.11	-.01	.23*	.01	.01	.02
	Site D	.82**	-.11	.01	-.06	.01	.05	.14
Empathy	Whole	-.71**	.08	-.03	.10*	.17**	-.04	-.13**
	Site A	-.92**	.17	-.05	.16	-.06	.09	.07
	Site B	-.90**	.20	.03	.02	-.02	-.03	.
	Site C	-.87**	.01	-.09	-.13	-.06	-.02	.01
	Site D	-.72**	.09	.09	.14	-.01	-.08	-.21*

Table 5. Results from multiple linear regression analyses: model summaries and significant coefficients with annoyance, anger, and empathy (* $p < 0.05$, ** $p < 0.01$).

Dependent Variable	<i>R</i>	<i>R</i> Square	Adjusted <i>R</i> Square	Variables	<i>B</i>	<i>SE B</i>	β	<i>t</i>	<i>p</i>	95% Confidence Interval for <i>B</i>	
										Lower Bound	Upper Bound
Annoyance	.85	.72	.71	(Constant)	-124.24	6.37		-19.52	**	-136.75	-111.73
				Slab thickness	0.11	0.04	0.10	2.83	**	0.03	0.18
				Building age	0.23	0.04	0.22	6.13	**	0.16	0.30
				Noise sensitivity	2.28	0.07	0.84	31.14	**	2.14	2.43
Anger	.90	.82	.81	(Constant)	-108.48	4.88		-22.23	**	-118.07	-98.88
				Slab thickness	0.30	0.03	0.34	8.88	**	0.23	0.36
				Building age	0.39	0.03	0.45	13.76	**	0.34	0.45
				Participant's age	-0.10	0.03	-0.07	-3.37	**	-0.16	-0.04
				Noise sensitivity	1.95	0.05	0.86	39.52	**	1.86	2.05
				Floor area	-0.09	0.04	-0.06	-2.25	*	-0.16	-0.01
Empathy	.87	.75	.75	(Constant)	165.12	3.82		43.26	**	157.61	172.62
				Slab thickness	-0.44	0.03	-0.77	-17.06	**	-0.49	-0.39
				Building age	-0.37	0.02	-0.66	-16.94	**	-0.42	-0.33
				Participant's age	0.06	0.02	0.06	2.46	*	0.01	0.10
				Occupation	0.06	0.02	0.09	3.35	**	0.02	0.09
				Noise sensitivity	-1.09	0.04	-0.73	-28.86	**	-1.16	-1.01
				Floor area	0.20	0.03	0.23	6.96	**	0.14	0.26

References

- [1] Jeon JY, Lee PJ, Kim JH, Yoo SY. Subjective evaluation of heavy-weight floor impact sounds in relation to spatial characteristics. *J Acoust Soc Am*. 2009;125:2987-94.
- [2] Jeon JY, Hong JY, Kim SM, Lee PJ. Classification of heavy-weight floor impact sounds in multi-dwelling houses using an equal-appearing interval scale. *Build Environ*. 2015;94:821-8.
- [3] Jeon JY, Lee PJ, Sato S. Use of the standard rubber ball as an impact source with heavyweight concrete floors. *J Acoust Soc Am*. 2009;126:167-78.
- [4] Statistics Korea. Complete enumeration results of the 2016 population and housing census. Republic of Korea: Statistics Korea; 2017.
- [5] Office for National Statistics. Families and Households: 2017. UK: Office for National Statistics; 2017.
- [6] Liu L, Rohdin P, Moshfegh B. Evaluating indoor environment of a retrofitted multi-family building with improved energy performance in Sweden. *Energy and Buildings*. 2015;102:32-44.
- [7] Floor Noise Management Centre. Monthly report: May 2018. Republic of Korea: Floor Noise Management Centre, Korea Environment Corporation; 2018.
- [8] Park KH. Criminal study on the noise: Focused on the floor impact noise dispute. *Inha Law Review*. 2015;18:297-328.
- [9] Lee PJ, Kim JH, Jeon JY. Psychoacoustical characteristics of impact ball sounds on concrete floors. *Acta Acust United Ac*. 2009;95:707-17.
- [10] Nagano K, Horikoshi T. New comfort index during combined conditions of moderate low ambient temperature and traffic noise. *Energy and Buildings*. 2005;37:287-94.
- [11] Ljunggren F, Simmons C, Hagberg K. Correlation between sound insulation and occupants' perception-Proposal of alternative single number rating of impact sound. *Appl Acoust*. 2014;85:57-68.
- [12] Ljunggren F, Simmons C, Öqvist R. Correlation between sound insulation and occupants' perception: Proposal of alternative single number rating of impact sound, Part 2. *Appl Acoust*. 2017;123:143-51.
- [13] Park SH, Lee PJ. Effects of floor impact noise on psychophysiological responses. *Build Environ*. 2017;116:173-81.
- [14] Park SH, Lee PJ, Jeong JH. Effects of noise sensitivity on psychophysiological responses to building noise. *Build Environ*. 2018;136:302-11.
- [15] Jeon JY, Ryu JK, Jeong JH, Tachibana H. Review of the impact ball in evaluating floor impact sound. *Acta Acust United Ac*. 2006;92:777-86.
- [16] Kim MJ, Sohn JY, Kim HS. An Experimental Study on the Effect Factors of Floor Impact Sound Performance for Apartment Housing. *Journal of the Architectural Institute of Korea: Planning & Design*. 1998;14:167-78.
- [17] Huang EHC. Field floor impact noise south-east Queensland (Australia). INTER-NOISE and NOISE-CON Congress and Conference. Melbourne, Australia: Institute of Noise Control Engineering; 2014. p. 1634-41.
- [18] Kimura S. Development of floor impact sound insulation technology in Japan. *J Acoust Soc Am*. 1996;100:2768-.
- [19] Jeon JY, Yoo SY, Jeong Y, Jeong JH. The effect of the design elements of reinforced concrete slab on heavy-weight floor impact noise. *Journal of the Architectural Institute of Korea: Planning & Design*. 2006;22:329-36.
- [20] Yeon JO, Kim KW, Yang KS. A correlation between a single number quantity and noise level of real impact sources for floor impact sound. *Appl Acoust*. 2017;125:20-33.

- [21] Ministry of Construction and Transportation. Criteria on the authorization and management of block structures for floor impact sounds in multi-dwelling houses. Republic of Korea: 2005.
- [22] Ministry of Land, Infrastructure and Transport. Presidential decree for the regulations on housing construction standards, etc. (No. 28243). Republic of Korea: 2018.
- [23] Park SH, Lee PJ, Lee BK. Levels and sources of neighbour noise in heavyweight residential buildings in Korea. *Appl Acoust.* 2017;120:148-57.
- [24] Job RFS. Community response to noise: A review of factors influencing the relationship between noise exposure and reaction. *J Acoust Soc Am.* 1988;83:991-1001.
- [25] Park SH, Lee PJ, Jeong JH. Emotions evoked by exposure to footstep noise in residential buildings. *Plos One.* 2018;13:e0202058.
- [26] Kryter KD. *The Effects of Noise on Man*: Academic Press; 1970.
- [27] Fields JM, de Jong RG, Gjestland T, Flindell IH, Job RFS, Kurra S, et al. Standardized general-purpose noise reaction questions for community noise surveys: Research and a recommendation. *J Sound Vib.* 2001;242:641-79.
- [28] ISO. *Assessment of noise annoyance by means of social and socio-acoustic surveys*. Geneva, Switzerland: International Organization for Standardization (ISO); 2003.
- [29] Laszlo HE, McRobie ES, Stansfeld SA, Hansell AL. Annoyance and other reaction measures to changes in noise exposure: A review. *Sci Total Environ.* 2012;435-436:551-62.
- [30] Weinstein ND. Individual differences in reactions to noise: A longitudinal study in a college dormitory. *Journal of Applied Psychology.* 1978;63:458-66.
- [31] Steiger JH. Tests for Comparing Elements of a Correlation Matrix. *Psychological Bulletin.* 1980;87:245-51.
- [32] Friedrichs J, Blasius J. Attitudes of owners and renters in a deprived neighbourhood. *European Journal of Housing Policy.* 2009;9:435-55.
- [33] Rylander R, Björkman M, Åhrlin U, Sörensen S, Berglund K. Aircraft noise annoyance contours: Importance of overflight frequency and noise level. *J Sound Vib.* 1980;69:583-95.
- [34] Fields JM, Walker JG. Comparing the relationships between noise-level and annoyance in different surveys: A railway noise vs. aircraft and road traffic comparison. *J Sound Vib.* 1982;81:51-80.
- [35] Fields JM. Effect of personal and situational variables on noise annoyance in residential areas. *J Acoust Soc Am.* 1993;93:2753-63.
- [36] Miedema HME, Vos H. Demographic and attitudinal factors that modify annoyance from transportation noise. *J Acoust Soc Am.* 1999;105:3336-44.
- [37] Miedema HME, Vos H. Exposure-response relationships for transportation noise. *J Acoust Soc Am.* 1998;104:3432-45.
- [38] Park SH, Lee PJ, Yang KS. Perception and reaction to floor impact noise in apartment buildings: A qualitative approach. *Acta Acust United Ac.* 2016;102:902-11.
- [39] Lee SW. Impact Sound Insulation Characteristics of Floors according to the number of P'yong and Layers. *The International Journal of The Korea Institute of Ecological Architecture and Environment.* 2004;4:71-8.
- [40] Hirakawa S, Hopkins C. Experimental determination of transient structure-borne sound power from heavy impact sources on heavyweight floors with floating floors using an inverse form of transient statistical energy analysis. *Appl Acoust.* 2018;140:74-82.
- [41] Jeon JY, Lee PJ, You J, Kang J. Perceptual assessment of quality of urban soundscapes with combined noise sources and water sounds. *J Acoust Soc Am.* 2010;127:1357-66.
- [42] Schreckenber D. The association between residential quality of life and aircraft noise annoyance around Frankfurt Airport. *Acoustics '08 Paris*. Paris, France 2008. p. 9479-84.

- [43] Fields JM. Effect of personal and situational variables on noise annoyance: With special reference to implications for en route noise. In: Fields JM, editor.: National Aeronautics and Space Administration (NASA); 1992.
- [44] Park SH, Lee PJ, Yang KS, Kim KW. Relationships between non-acoustic factors and subjective reactions to floor impact noise in apartment buildings. *J Acoust Soc Am*. 2016;139:1158-67.
- [45] Ryu JK, Jeon JY. Influence of noise sensitivity on annoyance of indoor and outdoor noises in residential buildings. *Appl Acoust*. 2011;72:336-40.
- [46] Chavis DM, Hogge JH, McMillan DW, Wandersman A. Sense of community through Brunswik's lens: A first look. *Journal of Community Psychology*. 1986;14:24-40.
- [47] Buckner JC. The development of an instrument to measure neighborhood cohesion. *American Journal of Community Psychology*. 1988;16:771-91.
- [48] Baek GO, Mun DH, Han HK, Park HG. Analysis of heavy-weight floor impact noise and vibration of concrete slabs in a residential building. *World Congress on Advances in Civil, Environmental, and Materials Research*. Incheon, Republic of Korea 2015.

Site A

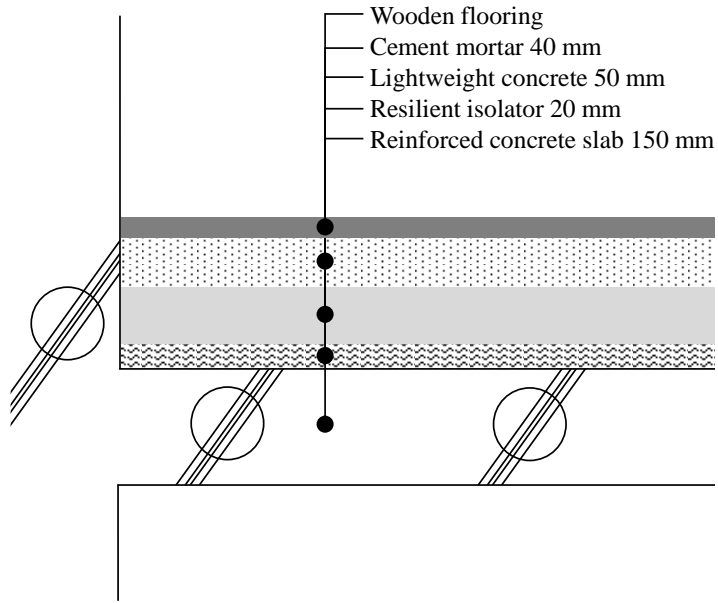

Site B

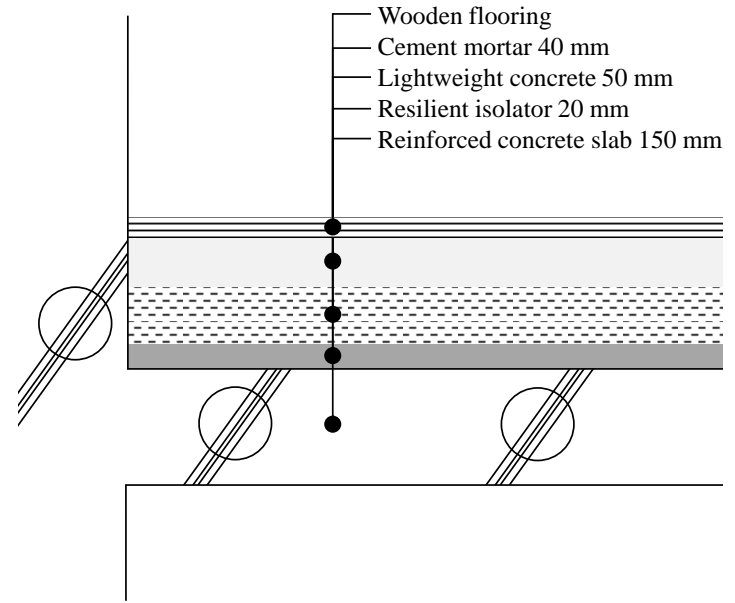

Site C

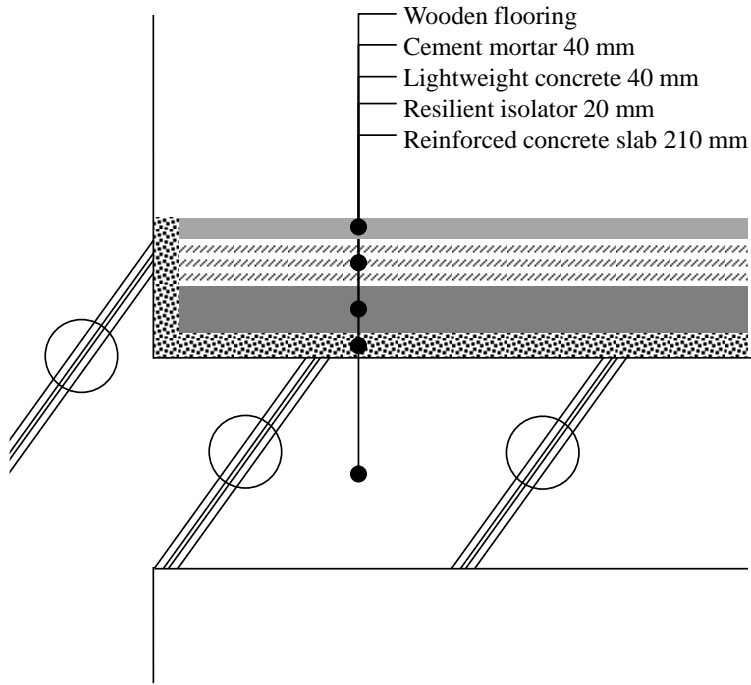

Site D

