



ELSEVIER

Contents lists available at ScienceDirect

European Journal of Operational Research

journal homepage: www.elsevier.com/locate/ejor

Decision Support

Push or Pull? The impact of ordering policy choice on the dynamics of a hybrid closed-loop supply chain

Junyi Lin^a, Li Zhou^b, Virginia L. M. Spiegler^c, Mohamed M. Naim^{d,e}, Aris Syntetos^{d,e}^a International Business School Suzhou (IBSS), Xi'an Jiaotong-Liverpool University, China^b Faculty of Business, University of Greenwich, UK^c Department of Analytics, Operations and Systems, Kent Business School, University of Kent, UK^d Logistics Systems Dynamics Group, Cardiff Business School, Cardiff University, UK^e PARC Institute of Manufacturing, Logistics and Inventory, Cardiff Business School, Cardiff University, UK

ARTICLE INFO

Article history:

Received 2 December 2020

Accepted 13 October 2021

Available online xxx

Keywords:

System dynamics

Closed-loop supply chains

Bullwhip effect

Push and pull production

Nonlinear dynamics

ABSTRACT

We study the dynamic behaviour of a hybrid system where manufacturing and remanufacturing operations occur simultaneously to produce the same serviceable inventory for order fulfilment. Such a hybrid system, commonly found in the photocopier and personal computer industries, has received considerable attention in the literature. However, its dynamic performance and resulting bullwhip effect, under push and pull remanufacturing policies, remain unexplored. Relevant analysis would allow considering the adoption of appropriate control strategies, as some of the governing rules in a push-based environment may break down in pull-driven systems, and vice versa. Using nonlinear control theory and discrete-time simulation, we develop and linearise a nonlinear stylised model, and analytically assess bullwhip performance of push- and pull-controlled hybrid systems. We find the product return rate to be the key influencing factor of the order variance performance of pull-controlled hybrid systems, and thus, to play an important role towards push or pull policy selection. Product demand frequency is another important factor, since order variance has a U-shaped relation to it. Moreover, the product return delay shows a supplementary impact on the system's dynamics. In particular, the traditional push-controlled hybrid system may be significantly influenced by this factor if the return rate is high. The results highlight the importance of jointly considering ordering structure and product demand characteristics for bullwhip avoidance.

© 2021 The Author(s). Published by Elsevier B.V.

This is an open access article under the CC BY license (<http://creativecommons.org/licenses/by/4.0/>)

1. Background and contribution

Closed-loop supply chains (CLSCs) can generate profits by taking back products from customers and recovering the remaining value, as well as providing environmental benefits by avoiding sending end-of-life products into landfill (Guide & Van Wassenhove, 2009). The value of CLSCs has been estimated at €30 billion in the European Union alone (European Remanufacturing Network, 2015), and the European Commission aims to increase the value of Europe's remanufacturing sector by up to €100 billion by 2030. And in the United States of America, remanufacturing operations are already supporting at least 180,000 full-time jobs (Dominguez, Ponte, Cannella & Framinan, 2019).

We study the dynamic performance of a hybrid CLSC, focusing on the bullwhip effect with push- and pull-controlled remanufacturing policies. The hybrid CLSC refers to a system where manufactur-

ing and remanufacturing operations occur simultaneously to produce the same serviceable inventory for order fulfilment (Van Der Laan, Salomon, Dekker & Van Wassenhove, 1999). The bullwhip effect refers to a phenomenon in which low variations in marketplace demand cause significant changes in upstream production for suppliers, with associated costs such as the ramping down and ramping up of machines, hiring and firing of staff, and excessive inventory levels (Ponte, Framinan, Cannella & Dominguez, 2020; Wang & Disney, 2016). The bullwhip effect (Lee et al., 1997) plays a critical role in influencing supply chain performance under the already volatile conditions of the current business environment (Spiegler & Naim, 2017). Understanding the dynamics of CLSCs and reducing their bullwhip levels can help improve their operational performance and economic viability (Hosoda & Disney, 2018).

However, only a small number of studies have explored the dynamics of remanufacturing systems with the bullwhip effect seen as an increasingly important performance indicator for hybrid CLSCs settings (Goltsov et al., 2019; Ponte et al., 2020). An even more limited number of studies have systematically and com-

E-mail addresses: Junyi.Lin@xjtlu.edu.cn (J. Lin), Li.Zhou@gre.ac.uk (L. Zhou), V.L.Spiegler@kent.ac.uk (V.L.M. Spiegler).

<https://doi.org/10.1016/j.ejor.2021.10.031>

0377-2217/© 2021 The Author(s). Published by Elsevier B.V. This is an open access article under the CC BY license (<http://creativecommons.org/licenses/by/4.0/>)

paratively assessed the impact of push- and pull-based remanufacturing production on the bullwhip effect, although some researchers have analysed the individual impact of both production policies with meaningful insights obtained (e.g. Ponte, Naim & Syntetos, 2019; Tang & Naim, 2004; M. Turrisi, Bruccoleri & Cannella, 2013; Zhou & Disney, 2006; Zhou, Naim & Disney, 2017). This makes it difficult to consider the adoption of different control policies, as some of the governing rules in a push-based environment may break down in pull-driven systems and vice versa. Practically, based on our remanufacturing project funded by the UK Engineering and Physical Sciences Research Council (EPSRC) we found most project partner companies adopted a push-based production control policy (e.g. the Order-Up-To policy) for their remanufacturing and CLSCs. As a result, motivated by academic gaps and practical observation, the following fundamental question is answered:

Which of the classic production policies, push or pull, in the remanufacturing process yield the greatest benefits in improving dynamic behaviour, especially bullwhip performance, in a hybrid CLSC system?

Therefore, we argue that the systematic comparison of push- and pull-controlled remanufacturing dynamics in CLSCs is not yet fully understood. Below we discuss findings from the extant literature, highlighting relevant discrepancies that we will account for in the present paper.

1.1. Research on the dynamics of CLSCs systems

The dynamic performance of traditional forward, or open-loop, supply chains has been extensively studied. The outcome of such research has led to a comprehensive understanding of the impact of system structure on bullwhip and inventory variance (Serman, Oliva, Linderman & Bendoly, 2015). This includes the impact of feedback loops and delays (Lin, Naim, Purvis & Gosling, 2017), nonlinearities (Lin, Naim & Spiegler, 2020; Lin & Naim, 2019; Spiegler & Naim, 2017), stocks and flows (Weinhardt, Hendijani, Harman, Steel & Gonzalez, 2015) and the interplay of human decision-making heuristics with systems structure (Croson, Donohue, Katok & Serman, 2014; Wu & Katok, 2006). Methodologically, System Dynamics simulation (Besiou et al. 2014), Control Theory (Lin, Spiegler & Naim, 2018; Udenio, Vatamidou, Fransoo & Dellaert, 2017), Agent-based modelling (Cannella, Di Mauro, Dominguez, Ancarani & Schupp, 2019; Costas, Ponte, de la Fuente, Pino & Puche, 2015) and empirical methods (Bendoly, Swink & Simpson III, 2014, Moritz, Siemsen & Kremer, 2014) have been recognized for studying supply chain dynamic behaviour.

Within the context of CLSCs, the exploration of dynamic performance is far more limited. Goltsov et al.'s (2019) systematic literature review reported only 19 academic papers assessing the system dynamics performance of remanufacturing systems and CLSCs. Tang & Naim (2004) were the first to investigate a single echelon, push-based hybrid system considering the impact of different information sharing mechanisms on bullwhip and inventory variance. Under the similar push-based hybrid system setting, Zhou & Disney (2006) derived an order variance ratio measure using Åström's method. They found that the return rate plays a significant role in influencing bullwhip and inventory variance, while this is not the case for remanufacturing lead times. Georgiadis, Vlachos & Tagaras (2006) investigated a pure CLSC system by focusing on how the impact of lifecycles and return patterns of various products affect the optimal policies regarding expansion and contraction of collection and remanufacturing capacities. Furthermore, M. Turrisi et al. (2013) developed a specific CLSC model for managing CLSCs by considering the work-in-progress in the reverse flow of materials and have shown that these may generate a better dynamic performance in terms of order and inventory variability. Using combined System Dynamics simulation and Control Theory,

Zhou et al. (2017) extended the model by Tang & Naim (2004) to three-echelons and showed that the dynamic performance of the supply chain generally, but not always, benefits from reverse logistics.

Regarding pull-controlled hybrid CLSCs, Zhou, Naim, Tang & Towill (2006) studied the influence of Kanban-based remanufacturing lead times, return rate and forecasting policy on bullwhip and inventory variance performance. Furthermore, Dev, Shankar & Choudhary (2017) examined how stochastic demand and return rates, stochastic manufacturing and remanufacturing lead times, impact on system dynamics performance by developing simulation models for five different cases from the literature concerning continuous and periodic review systems.

In general, the above studies agree that return rate, remanufacturing lead times and forecasting policies play key roles in influencing dynamic performance. However, no study comparatively assesses the impact of pull and push remanufacturing policies on a hybrid CLSC's dynamic performance. Instead, the focus of previous studies is to compare the system dynamics performance between traditional forward supply chain systems and their proposed CLSC models, highlighting the benefits of adopting remanufacturing on reducing bullwhip to sit alongside the 'environment-friendly' nature of remanufacturing.

Furthermore, all such previous analytical studies are based on the fundamental linear assumption of their CLSC models (e.g. Ponte et al., 2019; Tang & Naim, 2004; Zhou et al., 2006, 2017). This ignores those common nonlinearities, such as forbidden returns and capacity constraints, present in real-world CLSCs systems. When linear assumptions are removed complex dynamic behaviours are revealed. More importantly, oscillations generated internally by the system itself, rather than by the external environment, may arise. Although some simulation works consider the nonlinearity factor in the CLSCs, simulating complex systems without having first done some preliminary mathematical analysis can be time intensive and lead to a trial-and-error approach that may hamper the system improvement process (Goltsov et al., 2019; Lin et al., 2017).

Several recent works analytically studied some forms of nonlinearities in traditional forward supply chain systems, such as capacity (Spiegler, Naim, Towill & Wikner, 2016) and non-negative order constraints (Wang, Wang & Ouyang, 2015). However, no study focuses on CLSCs systems and even those previous nonlinear studies on forward supply chains are restricted to the investigation of memoryless nonlinearities where the output of a nonlinear component only depends on the current state of input, while more complex nonlinear elements with memory, where the output depends not only on the current state but also is a function of first order derivative of the input (i.e. past state of the input), still remains unexplored. Recoverable inventory constraints in hybrid CLSCs, for example, is a typical such nonlinearity existing in pull-controlled hybrid CLSCs environment. This is because the remanufacturing order rate, or output, not only depends on the current state of the input, i.e. desired remanufacturing order rate, but also depending on the slope of the input that leads to the different recoverable inventory constraint states.

1.2. Contribution

Motivated by the theoretical gaps and practical observations, this paper aims to study the system dynamics performance of hybrid CLSCs, focusing on the bullwhip effect, under pull and push controlled remanufacturing environments. Our key contributions are:

- 1 We compare the bullwhip of the CLSCs under remanufacturing *push* and *pull* policies, contributing to a policy selection strat-

egy from system dynamics perspective. We derive the bullwhip formulation as a function of the inherent hybrid CLSCs system structure, including feedback loops, ordering policies, physical lead times and forecasting, and external product demand characteristics, highlighting the importance of jointly considering system structure and product demand characteristics for bullwhip avoidance.

- 2 We analytically assessing the impact of recoverable inventory constraints on the bullwhip effect that to the best of our knowledge, is the first work to study the nonlinear hybrid CLSC systems from a system dynamics perspective. Mathematically approximate closed-form results are derived to predict the propagation of order fluctuations. The easy-implementable method also is applicable for investigating other similar nonlinearities present in supply chain systems, e.g. shipment and state-dependant capacity constraints.

The rest of the paper is organised as follows. Section 2 presents the hybrid CLSCs model. Section 3 introduces the main analysis method adopted in this study with the detailed dynamic analysis undertaken in Section 4. This is followed by extensive numerical simulation in Section 5 before a final discussion and conclusion in Section 6.

2. Model

Notations for the hybrid system

Notation	Descriptions
C_m	Manufacturing completion rate
C_r	Remanufacturing completion rate
D_c	Customer demand rate
\hat{D}_c	Estimated demand rate
DO_t	Desired total order rate
I_s	Serviceable inventory level
I_r	Recoverable inventory level
O_m	Manufacturing order rate
O_r	Remanufacturing order rate
R_r	Returned product rate
RO_t	Re-order point
W_m	Manufacturing work-in-process inventory
W_r	Remanufacturing work-in-process inventory
W_c	The remain-in-use products
τ_m	Manufacturing lead time
τ_r	Remanufacturing lead time
τ_c	Customer in-use lead time
$\hat{\tau}_p$	Estimated lead time for achieving zero inventory offset
τ_a	Forecasting smoothing factor
α	Return proportion
β	Safety stock

2.1. Preliminaries

Consider a hybrid production system in which manufacturing and remanufacturing operations occurs simultaneously, if necessary, to produce serviceable inventory for customer order fulfilment. The processes, goods and information-flows, and stocking points of the hybrid system, based on van der

Laan et al. (1999), van der Laan & Teunter (2006) and Ponte et al. (2019), are visualised in Fig. 1. Such a hybrid system can be frequently observed in many industries. e.g. Spare part (Souza 2013), Consumer electronic (Zhou et al., 2017) and Furniture (van der Laan & Teunter, 2006). Specifically, the manufacturer collects used products from customers, and those products enter the disassembly process including inspection, cleaning and disassembly operations. A quality test then is conducted after disassembly. Qualified products will enter the remanufacturing production line, including repair, upgrading, and testing operations. Furthermore, due to a possible insufficiency in the returns and remanufacturing pro-

cess, a manufacturing production line, using virgin materials, may also produce the serviceable inventory for customers.

Manufacturing and remanufacturing are assumed as two independent production lines and there is a perfect substitution for newly manufactured and remanufactured products, i.e. the remanufactured product is as good as new product. The perfect substitution and independent production are common assumptions for exploring the dynamics of CLSCs (Zhou et al., 2017; Hosoda and Disney, 2018; Ponte et al., 2019; Hosoda, Disney & Zhou, 2021). The perfect substitution is also assumed in economic studies using game theory (e.g. Savaskan, Bhattacharya, & Van Wassenhove, 2004; Atasu, Toktay, & Van Wassenhove, 2013). Furthermore, perfect substitution can be frequently observed in practice. For instance, a Japanese beverage company called Suntory has developed remanufacturing technology for good-as-new PET bottles (Suntory, 2019). Personal computer giant HP remanufactured its toner cartridges worldwide via a closed loop cartridge recycling program named 'Planet Partners' (Nichols, 2014).

In the hybrid system of Fig. 1, the remanufacturing process can be controlled by either a *push* or *pull* strategy (van der Laan & Teunter, 2006; Van Der Laan et al., 1999). Under a push policy, all returned products are batched and pushed into the remanufacturing line immediately after disassembly and testing. On the other hand, a pull policy ensures the hybrid system only remanufactures the required orders to satisfy customer demand, i.e. it enables remanufacturing activities to delay the production as late as is convenient. The push and pull remanufacturing production are well recognised in studying the dynamics of CLSCs (e.g. Zhou et al., 2006, 2017; Hosoda et al., 2021). It also fits well with sustainability (Hosoda & Disney, 2018) and can be frequently observed in practice (Ponte et al., 2019). It should be noted that different from Van Der Laan et al. (1999), we model the remanufacturing pull based on the principle of *remanufacturing priority*. That is, the remanufacturing activity is always prioritized if there is sufficient recoverable inventory. Remanufacturing priority can reflect both practical observations, e.g. HP's toner cartridges recycling production (Nichols, 2014), as well as government policy requirements, e.g. EU's green deal (European Remanufacturing Network 2015).

2.2. Assumptions

We develop a stylized model of the hybrid manufacturing/remanufacturing system. All notations used in this paper are presented in Table 1. We replicate the dynamics of the hybrid system at a single-product level. Such systems occur in practice for copier modules and car parts (Van Der Laan et al., 1999). Different from the application of stochastic theory in studying supply chain dynamics, our model is fundamentally deterministic. This is because we analyse the complex dynamic behaviour (i.e. bullwhip) driven by ordering policies, feedback loops, nonlinearities and delays, which is determined by various deterministic cause-and-effect relationships between variables. The analysis derived from the deterministic model, also, can assist long-term, strategic planning (e.g. capacity planning, labour expansion, inventory holding) and offers the benchmark of system dynamics performance for subsequent dis-aggregate dynamic modelling and analysis (Größler, Thun & Milling, 2008; Lin & Naim, 2019). There are several general assumptions:

Remanufacturing process: A proportional of sold products, after considerable customer in-use lead time, will be returned and eventually become *qualified recoverable inventory* via the disassembly procedures including inspection, cleaning and disassembly operations, while others are directly sent to landfills for disposal. We define such recoverable inventory as *returned products* and assume

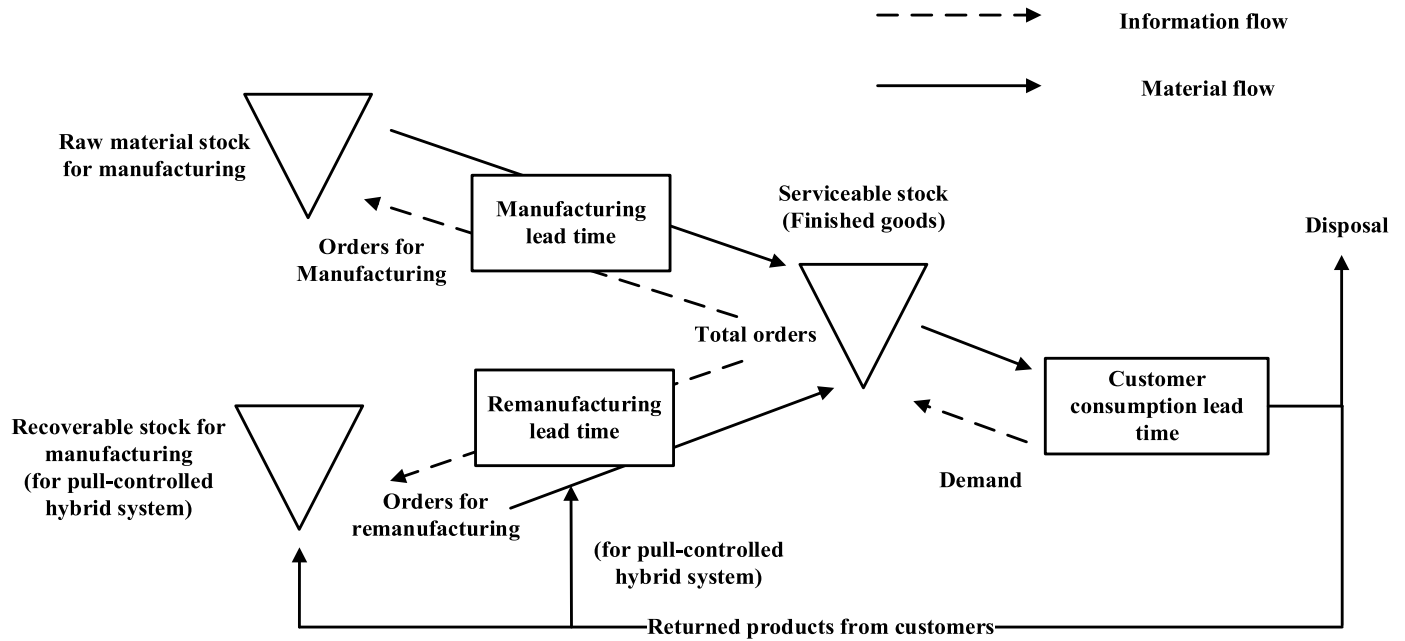

Fig. 1. Information and material flow of the hybrid manufacturing and remanufacturing system (based on Laan et al., 1999, van der Laan & Teunter, 2006 and Ponte et al., 2019).

all of them will be remanufactured, i.e. there is no further disposal once returned products are collected. After the remanufacturing process, finished goods are entered into serviceable inventory for satisfying incoming customer demand. In line with Hosoda, Disney & Gavirneni (2015), Ponte et al. (2019), Hosoda and Disney (2018) and Hosoda et al. (2021), the remanufacturing process has unlimited capacity and an average lead times is assumed. Practically, by removing capacity constraint, we can analytically trace the capacity unevenness issue identified in some industries, e.g. Semiconductor (Karabuk & Wu, 2003; Lin et al., 2018), which is driven by reactive dynamic capacity adjustment. That is, managers reactively adjust production capacity as they can determine maximum capacity requirement, leading to capacity unevenness. Also, capacity constraints may not be an issue if the CLSCs companies deploy the outsourcing or return regulation strategies (Ponte et al., 2019). Furthermore, unlimited capacity assumption allows for the in-depth investigation of recoverable inventory constraint on dynamic behaviour under push and pull remanufacturing control.

Manufacturing process: The manufacturing line simultaneously produces the new products but only if necessary. Raw materials, supplied by qualified suppliers, arrive in a just-in-time manner, that is, no raw material inventory is held. Also, there is no capacity limit for manufacturing and all finished goods are stocked in serviceable inventory to meet customer demand.

Stock points, returns and backlog orders: All stock points' capacities are infinite. Following Tang & Naim (2004) and Zhou et al. (2017), we also assume that there is a deterministic correlation between demand and returns, denoted by the α , $\forall \alpha \in (0, 1)$, after a considerable in-use delay. For the system controlled by the push policy, there is no serviceable inventory stock point as all returned products are immediately batched and pushed into the remanufacturing line. However, for the pull policy, a serviceable stock point is presented, as the remanufacturing line only produces required products as late as is convenient. Also, demands that cannot be fulfilled immediately are backordered and backlog orders are presented by the negative serviceable inventory. Furthermore, we allow the return between the hybrid producer and raw material supplier, i.e. the possible negative order is allowed. For the impact of non-negative order constraints on sys-

tem dynamics, the reader may refer to Wang et al. (2012); Wang et al. (2015), Spiegler & Naim (2017) and Lin & Naim (2019) for details.

2.3. System dynamics models

The order-up-to (OUT) policy for inventory replenishment (continuous review) is adopted:

$$DO_t = RO_t - (I_s + W_m + W_r) \quad (1)$$

$$RO_t = \widehat{D}_c \cdot \widehat{\tau}_p + \beta \quad (2)$$

$$\frac{d\widehat{D}_c}{dt} = \frac{D_c - \widehat{D}_c}{\tau_a} \quad (3)$$

where desired total order rate (DO_t) aims to bring system inventory, including serviceable and work-in-process inventory ($I_s + W_m + W_r$), up to the re-order point (RO_t). RO_t depends on the estimated demand rate (\widehat{D}_c) during estimated lead time ($\widehat{\tau}_p$) that determines any inventory-offset error (Zhou et al., 2017), plus a constant β (e.g. days, weeks' supply), although other approaches such as setting as a function of forecasted demand (Springer & Kim, 2010) can be considered. Also, the exponential smoothing forecasting technique is applied for estimating \widehat{D}_c with smoothing parameter τ_a (Zhou et al., 2006, 2017). Moreover, serviceable inventory level (I_s) is the cumulative level between manufacturing and remanufacturing completion rate ($C_m + C_r$) and customer demand (D_c), i.e. while the D_c depletes I_s , C_m and C_r replenish it:

$$\frac{dI_s}{dt} = C_m + C_r - D_c \quad (4)$$

where C_m and C_r are equal to the delayed manufacturing and remanufacturing order rate (O_m and O_r), determined by the corresponding work-in-process inventory (W_m and W_r) and lead times (τ_m and τ_r). A first order delay with deterministic τ_m and τ_r is assumed (Udenio et al., 2017), which can be interpreted as a production smoothing element representing the speed at which the production units adapt to changes in O_m and O_r (Lin et al., 2017).

$$\frac{dW_m}{dt} = O_m - C_m, \quad C_m = \frac{W_m}{\tau_m} \quad (5)$$

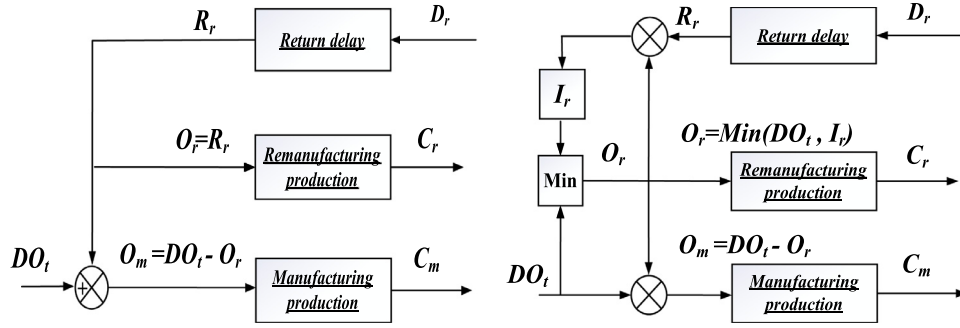

Fig. 2. Block diagram representation of remanufacturing push (Fig. 2a) and pull (Fig. 2b) policies.

$$\frac{dW_r}{dt} = O_r - C_r, \quad C_r = \frac{W_r}{\tau_r} \quad (6)$$

The relationship between DO_t , O_m and O_r is the order allocation process for manufacturing and remanufacturing production, and there are push and pull remanufacturing options (Van Der Laan et al., 1999), as shown in a block diagram form in Figs. 2a and 2b respectively.

All returned products (R_r) in the push policy immediately enter the remanufacturing line and thereby there is no recoverable inventory (Tang & Naim, 2004). Hence,

$$O_r(\text{push}) = R_r; \quad O_m(\text{push}) = DO_t - R_r \quad (7)$$

where a first order delay with W_c and τ_c is applied for modelling R_r (Zhou et al., 2017). The proportional parameter, $\alpha \in (0, 1)$, is introduced for representing the fact that possibly a proportion of D_c are eventually returned for remanufacturing, while others are directly sent to landfills for disposal.

$$\frac{dW_c}{dt} = \alpha \cdot D_c - R_r; \quad R_r = \frac{W_c}{\tau_c} \quad (8)$$

On the other hand, if the remanufacturing system is controlled by a pull policy, the total orders are always prioritized for the remanufacturing line subject to the availability of recoverable inventory (I_r):

$$O_r(\text{pull}) = \text{Min}(I_r, DO_t) \quad (9)$$

where I_r is the cumulative level between DO_t and R_r from customers. If remanufacturing cannot satisfy DO_t due to the limited I_r , O_m will produce the rest of orders required by DO_t .

$$\frac{dI_r}{dt} = R_r - DO_t \quad (10)$$

$$O_m(\text{pull}) = DO_t - O_r \quad (11)$$

In other words $O_m(\text{pull}) = 0$ if there are available I_r to satisfy DO_t , i.e. $O_r(\text{pull}) = DO_t$, while if I_r constrains the DO_t , manufacturing simultaneously produces for serviceable inventory to satisfy customer demand, that is, $O_r(\text{pull}) = I_r$, $O_m(\text{pull}) = DO_t - I_r$.

To summarise, we consider two remanufacturing policies in our stylised hybrid model under the OUT serviceable inventory replenishment strategy. If the push policy is adopted, there is no recoverable inventory as all returned cores are ‘pushed’ into the remanufacturing line regardless of serviceable inventory level. Given the unlimited capacity and return allowance assumption, the push-controlled hybrid system thereby is completely linear. The linear system follows the principle of *superposition*, which means that the system’s dynamic response given an input signal, e.g. $\mu_1 + \mu_2$, is the sum of the behaviour in signals of magnitude μ_1 and μ_2 applied separately (Lin et al., 2018) and therefore the well-known linear control approaches can be applied (Dejonckheere, Disney, Lambrecht & Towill, 2003).

However, the hybrid system under remanufacturing pull control creates the recoverable inventory stock in which the returned cores will only be remanufactured if necessary. The pull policy also prioritises remanufacturing production in responding to DO_t , i.e. Eq. (10) and (11). Therefore, these two Equations form a multi-valued nonlinearity in the remanufacturing order rate, dependant not only on the current state of the input, i.e. desired remanufacturing order rate, but also the slope of the input that leads to the different recoverable inventory constraint states.

3. Method

In this work, the sinusoid demand as the hybrid system input is assumed. The sinusoidal demand represents the predictable/seasonally unadjusted demand data, which is a major source of demand variability (Cachon, Randall & Schmidt, 2007) and commonly found in many industries, e.g. fashion (Li, Zhou & Huang, 2017) and agro-food (Jonkman, Barbosa-Póvoa & Bloemhof, 2019). Also, the result generated by sinusoid demand input is identical to the input being i.i.d. stochastic demand, i.e. the amplitude ratio value is exactly the same as the ratio of the standard deviations of i.i.d. input over output (Jakšić & Rusjan, 2008; Udenio et al., 2017). Furthermore, it is important to note that our interest is not restricted to the expectation of a sinusoidal demand. Since any demand stream can be decomposed into a sum of sinusoids, analysing the relevant frequency response plots (i.e. the graphical representation of the amplification ratio as a function of the demand harmonics with frequencies between zero and π) provides preliminary understanding about the performance of a system with regards to any arbitrary demand pattern based on the amplitude of its constituent harmonics (Dejonckheere et al., 2003). A manager therefore can design the system based on the ‘filter lens’ to appropriately track the ‘true’ message while rejecting ‘noise’ signals (Towill, Zhou & Disney, 2007).

Regarding methods adopted in this study, if the system is linear and time-invariant (LTI), frequency domain analysis, using Laplace transform and transfer function techniques, can be applied (Wang et al., 2015). The transfer function of a system is a mathematical representation describing the dynamic behaviour algebraically of a LTI system. If a sinusoidal input is assumed, the linear system will produce a sinusoidal output of the same frequency but of a different magnitude and phase. Thus, the steady state amplification ratio (i.e. bullwhip effect) can be measured by the ratio between the amplitude (variance) of orders and demand (Jakšić & Rusjan, 2008; Udenio et al., 2017).

However, classic linear techniques are no longer valid in nonlinear hybrid CLSCs controlled by remanufacturing pull, as described by Eqs. (10) and (11). As such a nonlinearity is characterised by a discontinuous piecewise linear function, the describing function (DF) method (Spiegler & Naim, 2017; Wang et al., 2015) will be applied for analysing the bullwhip effect. This method is a quasi-

linear representation for a nonlinear element subjected to specific input signal forms such as Bias, Sinusoid and Gaussian processes (Vander Velde, 1968). Describing function analysis normally requires that the input signal is either sinusoidal or dominated by low frequency components (Spiegler & Naim, 2017), while for high demand frequency, the aid of simulation is recommended to verify the analytical results (Wang et al., 2015). Specifically, for a given sinusoid input, $i_t = A \cdot \cos(\omega t) + B$, $\forall 0 \leq t < \infty$, the output o_t can be approximated:

$$o_t \approx N_{A(o_t)} \cdot A \cdot \cos(\omega t + \phi) + N_{B(o_t)} \cdot B \quad (12)$$

Where a is the amplitude, ω is the angular frequency and b is mean. Regarding the DF gains, $N_{A(o_t)}$ is the amplitude gain, $N_{B(o_t)}$ is the mean gain and ϕ is the phase shift. The basic idea of the DF method is to replace the nonlinear component by a type of transfer function, or a gain derived from the effect of the (sinusoidal) input. The Fourier series expansion can be applied to obtain the terms of DF.

$$\begin{aligned} o_t &\approx b_0 + a_1 \cdot \cos(\omega t) + b_1 \cdot \sin(\omega t) \\ &\quad + a_2 \cdot \cos(2\omega t) + b_2 \cdot \sin(2\omega t) + \dots \\ &\approx b_0 + \sum_{n=1}^{\infty} (a_n \cdot \cos(n\omega t) + b_n \cdot \sin(n\omega t)) \end{aligned} \quad (13)$$

where the Fourier coefficient can be determined by:

$$\begin{aligned} a_n &= \frac{1}{\pi} \int_{-\pi}^{\pi} o_t \cdot \cos(n\omega t) d_{\omega t}, \quad b_n = \frac{1}{\pi} \int_{-\pi}^{\pi} o_t \cdot \sin(n\omega t) d_{\omega t}, \\ b_0 &= \frac{1}{2\pi} \int_{-\pi}^{\pi} o_t \cdot d_{\omega t} \end{aligned} \quad (14)$$

To approximate a periodic series, only the first, or fundamental harmonic, is needed and hence we need to find the first order coefficient of Fourier series expansion demonstrated in Eq. (14).

$$O_t \approx b_0 + a_1 \cdot \cos(\omega t) + b_1 \cdot \sin(\omega t) = b_0 + \sqrt{a_1^2 + b_1^2} \cos(\omega t + \phi) \quad (15)$$

By comparing Eq. (15) and (12), we can obtain the gains of DF as follow:

$$N_{A(o_t)} = \frac{\sqrt{a_1^2 + b_1^2}}{a}, \quad N_{B(o_t)} = \frac{b_0}{b}, \quad \phi = \arctan\left(\frac{b_1}{a_1}\right) \quad (16)$$

In other words, given the sinusoidal input, the output of a discontinuous nonlinearity can be approximated, not only as the function of inherent system structure and policy, but also as a function of input properties, e.g. amplitude, mean and frequency.

4. Dynamic analysis

4.1. The serviceable inventory

Recall from Eq. (2) that the reorder point is set as a function of estimated lead time, $\hat{\tau}_p$, which is assumed equal to actual manufacturing lead time, τ_m , to avoid inventory drift, i.e. the permanent inventory error from the target inventory (Disney & Towill, 2005). In the hybrid system, to avoid the permanent inventory error, the

$$DO_t(t) = \frac{A \sin(\omega t) (\tau_a - 1 - \omega^2 + \omega^2 (\tau_a^3 + \hat{\tau}_p (\tau_a^2 - 1))) - A \omega \cos(\omega t) (\tau_a - 1) (\omega^2 \tau_a (1 + \tau_a) + \hat{\tau}_p (\omega^2 \tau_a - 1))}{(1 + \omega^2) (\tau_a - 1) (1 + \omega^2 \tau_a^2)} + B \quad (21)$$

lead time estimation is more complex than in a traditional manufacturing system due to possible simultaneous manufacturing and remanufacturing production. This is explored by the following proposition:

Proposition 1: For the hybrid system following an order-up-to replenishment policy, regardless of push and pull controlled remanufacturing, the serviceable inventory drift can be avoided by setting adapted $\hat{\tau}_p$ as

$$\hat{\tau}_p = \tau_m (1 - \alpha) + \alpha \tau_r \quad (17)$$

Proof 1: See Tang & Naim (2004).

Given the existence of manufacturing and remanufacturing lead time variance, Eq. (17) highlights the importance of monitoring the hybrid system's real-time physical lead times and return rate to avoid either excessive inventory or stock-out issues. Also, if the return rate, α , is high, more attention should be paid to monitoring the remanufacturing lead time. This is particularly the case when such a hybrid system, initially in equilibrium, is disturbed by a sudden but sustained demand shock. Furthermore, if $\tau_m = \tau_r$, a production manager only needs to focus on lead time estimation for remanufacturing or manufacturing, since inventory drift can be avoided by $\hat{\tau}_p = \tau_m$ or $\hat{\tau}_p = \tau_r$.

4.2. Bullwhip for total order rate

The total order rate, DO_t , remains the same in both push and pull controlled remanufacturing process, due to the fundamental OUT policy adopted for replenishing the serviceable inventory. As a result, we derive the following proposition:

Proposition 2: Given sinusoid demand, $D_c = A \cos(\omega t) + B$, $\forall B \geq A > 0$, the order variance of DO_t for both push- and pull-controlled hybrid system, can be measured by:

$$OV(DO_t) = \sqrt{\frac{1 + (\omega + \omega(\hat{\tau}_p + \tau_a))^2}{(1 + \omega^2)(1 + \omega^2 \tau_a^2)}} \quad (18)$$

Proof 2: For simplicity, without losing generality, we assume $\beta=0$ (Zhou et al., 2017). The dynamic response of DO_t , in responding to D_c , can be derived by using Laplace transform technique:

$$\frac{DO_t}{D_c} = \frac{1 + s + s(\tau_a + \hat{\tau}_p)}{(1 + s)(1 + s\tau_a)} \quad (19)$$

The dynamic response of DO_t in responding to D_c in the time domain, using inverse Laplace transform of Eq. (19), can be derived:

$$\begin{aligned} DO_t(t) &= \frac{1}{(1 + \omega^2)(-1 + \tau_a)(1 + \omega^2 \tau_a^2)} \\ &\left(B(1 + \omega^2) \left(e^{-\frac{t}{\tau_a}} - 1 + \tau_a + \omega^2 \tau_a^3 - \omega^2 \tau_a^2 \right) \right. \\ &\quad - e^{-t} (B + B\omega^2 - A\omega) (\hat{\tau}_p + \tau_a) (1 + \omega^2 \tau_a^2) \\ &\quad + e^{-\frac{t}{\tau_a}} B \hat{\tau}_p (1 + \omega^2) (B\omega^2 \tau_a^2 - A\omega \tau_a^2) (1 + \hat{\tau}_p) \\ &\quad - A\omega \cos(\omega t) (\tau_a - 1) (\omega^2 \tau_a (1 + \tau_a) + \hat{\tau}_p (\omega^2 \tau_a - 1)) \\ &\quad \left. + A \sin(\omega t) (\tau_a - 1 - \omega^2 + \omega^2 \tau_a^3 + \omega^2 \hat{\tau}_p \tau_a^2 - \omega^2 \hat{\tau}_p) \right) \\ &, \quad 0 \leq t < \infty \end{aligned} \quad (20)$$

For a long-time response in equilibrium, $e^{-\frac{t}{\tau_c}} = e^{-t} = 0$. Eq. (20) can be re-arranged as:

Eq. (21) can be simplified as:

$$DO_t(t) = A \sqrt{\frac{1 + (\omega + \omega(\hat{\tau}_p + \tau_a))^2}{(1 + \omega^2)(1 + \omega^2 \tau_a^2)}} \cos$$

$$\times \left(\omega t - \tan^{-1} \left(\frac{\omega + \omega \tau_a}{1 - \omega^2 \tau_a} \right) + \tan^{-1} (\omega + \omega (\hat{\tau}_p + \tau_a)) \right) + B \quad (22)$$

The bullwhip of DO_t in responding to D_c , measured by the amplitude ratio, can be derived:

$$\begin{aligned} OV_{Push}(DO_t) &= \frac{\text{amplitude of } DO_t}{\text{amplitude of } D_t} = \frac{A \cdot \sqrt{\frac{1 + (\omega + \omega(\hat{\tau}_p + \tau_a))^2}{(1 + \omega^2)(1 + \omega^2 \tau_a^2)}}}{A} \\ &= \sqrt{\frac{1 + (\omega + \omega(\hat{\tau}_p + \tau_a))^2}{(1 + \omega^2)(1 + \omega^2 \tau_a^2)}} \end{aligned} \quad (23)$$

From Eq. (18), bullwhip exists if $OV(DO_t) > 1$, which depend on the system delays, forecasting parameter and demand frequency. Specifically, $OV(DO_t)$ increases in $\hat{\tau}_p$, and correspondingly, increases in τ_m and τ_r under the adapted $\hat{\tau}_p$ scenario, i.e. $\hat{\tau}_p = \tau_m(1 - \alpha) + \alpha \tau_r$. This supports the traditional view of long physical production lead times as one of the main sources of bullwhip induction (Ponte et al. 2017; 2019). An important insight here is the relative significance of manufacturing and remanufacturing lead times on the bullwhip level depending on return rate under adapted $\hat{\tau}_p$. If $\alpha < 0.5$, bullwhip is more significantly associated with τ_m than τ_r while if $\alpha > 0.5$ then bullwhip is more significantly associated with τ_r than τ_m . Furthermore, τ_m and τ_r play the same role in influencing $OV(DO_t)$ if $\alpha = 0.5$.

Also, $OV(DO_t)$ is independent of τ_c , suggesting that bullwhip is not influenced by the return delay of sold products. Furthermore, the impact of return rate, α , on bullwhip depends on the ratio between the manufacturing and remanufacturing lead times given $\hat{\tau}_p = \tau_m + \alpha(\tau_r - \tau_m)$, $\forall \alpha \in (0, 1)$. If $\frac{\tau_r}{\tau_m} > 1$, $\hat{\tau}_p$ is monotonically increasing in α and thereby $OV(DO_t)$ is a monotonically increasing function in α . In other word, bullwhip increases with the increase of return rate. On the other hand, if $\frac{\tau_r}{\tau_m} < 1$, $\hat{\tau}_p$ is a monotonically decreasing function in α and therefore bullwhip decreases with the increase of return rate. This implies that, if $\tau_r < \tau_m$, there is an economic incentive to increase the customer return rate to reduce the total bullwhip cost. This result is consistent with Tang & Naim (2004) and Zhou et al. (2017). Given $\hat{\tau}_p = \tau_m$ if $\tau_r = \tau_m$, then the return rate, α , plays no part on bullwhip of total order rate, while an increase manufacturing lead time results in greater bullwhip.

Regarding the impact of forecasting policy, we notice the following property by solving $OV(DO_t) \leq 1$ with respect to τ_a .

Property 1: bullwhip can be avoided by setting:

$$\tau_a \leq \frac{1 + \hat{\tau}_p + \sqrt{1 + \hat{\tau}_p(1 + \omega^2)(2 + \hat{\tau}_p)}}{\omega^2} \quad (24)$$

Property 1 shows that if the product demand cycle is slow (small value of ω), large value of τ_a , due to the denominator of Eq. (24), needs to be chosen to reduce or avoid bullwhip, although such a setting may lead to poor dynamic performance of serviceable inventory due to the slow recovery speed in responding to volatile demand (Dejonckheere, Disney, Lambrecht & Towill, 2002; Lin et al., 2018).

4.3. Bullwhip in push-controlled remanufacturing systems

If the remanufacturing process is controlled by a push policy, we have the following proposition for bullwhip measurement:

Proposition 3: If the hybrid CLSCs is controlled by a push policy, for a given sinusoid demand, $D_c = A \cos(\omega t) + B$, $\forall B \geq A > 0, t \in (0, \infty)$, order variance (OV) of O_r and O_m can be measured by:

$$OV_{Push}(O_r) = \alpha \sqrt{\frac{1}{1 + \omega^2 \tau_c^2}} \quad (25)$$

$$\begin{aligned} &OV_{Push}(O_m) \\ &= \sqrt{\frac{\omega^2((1 - \alpha)(\tau_a + 1) + \hat{\tau}_p + \tau_c)^2 + (1 - \alpha + \omega^2(\alpha \tau_a - \tau_c(1 + \hat{\tau}_p + \tau_c)))^2}{(1 + \omega^2)(1 + \omega^2 \tau_a^2)(1 + \omega^2 \tau_c^2)}} \end{aligned} \quad (26)$$

Proof 3. Since the push-controlled hybrid system is completely linear, the bullwhip of O_r and O_m can be derived using the Proof of Proposition 2.

From Eq. (25), remanufacturing cannot produce bullwhip in a push-based hybrid system, as $\alpha \sqrt{\frac{1}{1 + \omega^2 \tau_c^2}} < 1$ regardless of τ_a and ω (note that α ranges between 0 and 1). The $OV_{Push}(O_r)$ can be significantly decreased given an increase in ω and τ_c . This means that, for high frequency demand, with long life cycle products, the push-controlled remanufacturing can maintain a level schedule without concern of inducing high order variance. However, the manufacturing order rate may produce bullwhip, i.e. $OV_{Push}(O_m) > 1$. Regarding Eq. (26), by differentiating $OV_{Push}(O_m)$ with respect to α , it can be easily observed that an increase in α leads to a decrease in $OV_{Push}(O_m)$, suggesting that increasing the remanufactured product return rate, α , can reduce bullwhip in a push-controlled system. This result is consistent with previous literature (e.g. Ponte et al., 2020; Zhou & Disney, 2006; Zhou et al., 2017) that encourage product return so as to improve system dynamics performance by reducing bullwhip in the manufacturing process.

Although the additional proportional controller for inventory adjustment, that is, the proportional OUT (POUT), is advocated for system dynamics performance improvement (Wang and Disney 2017), it is important to note that in the hybrid OUT based model analysed here the only controllable policy is the forecasting adjustment. This provides the insight that one reliable way to eliminate bullwhip by carefully adopting a forecasting adjustment method based on customer demand. By further inspecting Eq. (26) with its first order derivative with respect to τ_a , it is shown that large value of τ_a reduces the manufacturing order variance.

4.4. Bullwhip analysis in pull-controlled hybrid systems

If the remanufacturing is controlled by a pull remanufacturing priority policy, that is, Eq. (10) and (11), then recoverable inventory stock, I_r , is created as the order is delayed as long as it is convenient. The O_r and O_m , thereby, can be expressed as:

$$O_r = \begin{cases} DO_t, & \text{if } DO_t < I_r \\ I_r, & \text{if } DO_t > I_r \end{cases}, \quad O_m = DO_t - O_r \quad (27)$$

Given the sinusoid demand, i.e. $D_c = A \cos(\omega t) + B, \forall B \geq A > 0, t \in (0, \infty)$, and proportional return rate assumption ($\alpha \in (0, 1)$), the hybrid system with pull-controlled remanufacturing policy has two different operating states:

$$\text{Operating State 1 : } O_r = I_r, \quad O_m = DO_t - O_r, \quad \forall DO_t > I_r, \quad t \in (0, \infty) \quad (28)$$

Operating State 2 : O_r

$$= \begin{cases} DO_t & | DO_t < I_r \\ I_r & | DO_t > I_r \end{cases}, \quad O_m = \begin{cases} 0 & | DO_t < I_r \\ DO_t - O_r & | DO_t > I_r \end{cases}, \quad \forall t \in (0, \infty) \quad (29)$$

Operating State 1 means that remanufacturing can never meet DO_t due to the I_r constraint, therefore, manufacturing and remanufacturing occur simultaneously to satisfy DO_t . Under such an operating state, the hybrid system is similar to the push-controlled

remanufacturing policy, where the returned cores immediately enter remanufacturing because recoverable inventory is always insufficient to satisfy the required DO_t . The bullwhip effect can be calculated using the analytical expression derived in Proposition 3.

Operating State 2, on the other hand, refers to fact that remanufacturing can possibly switch between I_r and DO_t during a cyclical demand, while manufacturing may intermittently replenish the required orders during the demand cycle.

So, under what conditions will the hybrid system operate as State 1 or State 2? We explore this question via the following proposition.

Proposition 4: For a given sinusoid demand, $D_c = A \cos(\omega t) + B$, $\forall B \geq A > 0$, $t \in (0, \infty)$, the hybrid CLSCs system controlled by pull-controlled policy operates under State 1 if

$$B - A \sqrt{\frac{1 + (\omega + \omega(\widehat{\tau}_p + \tau_a))^2}{(1 + \omega^2)(1 + \omega^2\tau_a^2)}} - \left(\frac{\alpha A}{\sqrt{1 + \omega^2\tau_c^2}} + \alpha B \right) \geq 0 \quad (30)$$

Otherwise the hybrid system operates under State 2.

Proof: See Appendix 1.2.

By differentiating the left side of Eq. (30) with respect to A , α and ω , we have the following property:

Property 2. For the hybrid CLSC system following a pull-controlled remanufacturing, the increase of demand amplitude and return rate leads to the switch from State 1 to State 2. However, an increase in demand frequency leads to a switch from State 2 to State 1.

Property 2 implies that the product demand and return characteristics play important roles in influencing the adoption of different remanufacturing control strategies. If the product demand is characterised as high demand frequency, low variability and high return rate, there is no major difference for push and pull-controlled remanufacturing strategies regarding the system dynamics performance, as the remanufacturing operates at State 1 under the pull-controlled policy. On the other hand, for long demand cycles with high variability and low return rate, the hybrid

CLSC with a pull-controlled remanufacturing policy will operate at State 2. Fig. 3 shows the plot of the value of $MinDO_t - MaxR_r$ as the function of ω , as well as the corresponding simulation verification, with the following system parameter settings as an example. $MinDO_t$ is the minimum value of the dynamic response of DO_t and $MaxR_r$ is maximum value of the dynamic response of R_r in D_c . As illustrated in the Proof of Proposition 4 (Appendix 1.2), the value of $MinDO_t - MaxR_r$ determines the different operating states.

$$D_c = 0.5 \cos(\omega t) + 1, \alpha = 0.5, \tau_a = 16, \tau_c = 32, \tau_m = 8, \tau_r = 4$$

Fig. 3a. $MinDO_t - MaxR_r$ as the function of ω Fig. 3b. $MinDO_t - MaxR_r = 0$ ($\omega = 0.97$ rad/week)

Fig. 3c. $MinDO_t - MaxR_r > 0$ ($\omega = 1.5$ rad/week) Fig. 3d. $MinDO_t - MaxR_r < 0$ ($\omega = 0.5$ rad/week)

Overall, the simulation verifies the analytical results of $MinDO_t - MaxR_r$. The crossover frequency, i.e. $\omega = 0.97$ rad/week, indicates that such a frequency leads to $MinDO_t - MaxR_r = 0$. Also, for $\omega = 0.5$ rad/week, $MinDO_t - MaxR_r < 0$, meaning the remanufacturing order rate (O_r) operates under State 2 condition. In other words, as DO_t and R_r are two independent variables, for a demand cycle O_r may be able to satisfy DO_t if $DO_t < R_r$ and therefore $DO_t < I_r$. However, O_r is constrained by I_r due to $DO_t > R_r$ hence $DO_t > I_r$. As a result, O_r may switch between DO_t and I_r during the demand cycle, leading to the complex nonlinear dynamics driven by the Operating State 2. We explore this phenomenon by the following proposition.

Proposition 5: If the hybrid CLSC is controlled by a pull-controlled policy under Operating State 2, for a given sinusoid demand, $D_c = A \cos(\omega t) + B$, $\forall B \geq A > 0$, $OV_{Pull}(O_r)$ and $OV_{Pull}(O_m)$ can be approximated by:

$$OV_{Pull}(O_r) \approx \sqrt{\frac{1 + (\omega + \omega(\widehat{\tau}_p + \tau_a))^2}{(1 + \omega^2)(1 + \omega^2\tau_a^2)}} \cdot DF(O_r) \quad (31)$$

$$OV_{Pull}(O_m) \approx \sqrt{\frac{1 + (\omega + \omega(\widehat{\tau}_p + \tau_a))^2}{(1 + \omega^2)(1 + \omega^2\tau_a^2)}} \cdot DF(O_m) \quad (32)$$

Where $DF(O_r)$ and $DF(O_m)$ can be computed by:

$$DF(O_r) = \frac{1}{4A} \sqrt{\left(\begin{aligned} &4B(1 + \alpha)(\cos(r_1) - \cos(r_2)) + \lambda_1 \left(\frac{\cos(2r_2 + \theta_1) - \cos(2r_1 + \theta_1) -}{4\pi \sin(\theta_1) + 2\sin(\theta_1)(r_2 - r_1)} \right) + \\ &\lambda_2(\cos(2r_1 + \theta_2) - \cos(2r_2 + \theta_2) + 2\sin(\theta_2)(r_1 - r_2)) \end{aligned} \right)^2 + \left(\begin{aligned} &4B(1 - \alpha)(\sin(r_1) - \sin(r_2)) + \lambda_1 \left(\frac{4\pi \cos(\theta_1) + \sin(2r_1 + \theta_1) -}{\sin(2r_2 + \theta_1) + 2\cos(\theta_1)(r_1 - r_2)} \right) + \\ &\lambda_2(\sin(2r_2 + \theta_2) - \sin(2r_1 + \theta_2) + 2\cos(\theta_2)(r_2 - r_1)) \end{aligned} \right)^2} \quad (33)$$

$$DF(O_m) = \frac{1}{4A\pi} \sqrt{\left(\begin{aligned} &4B(\alpha - 1)(\sin(r_1) - \sin(r_2)) + \lambda_1(-\sin(2r_1 + \theta_1) + \sin(2r_2 + \theta_1) + 2\cos(\theta_1)(r_2 - r_1)) + \\ &2\lambda_2(\cos(r_1 + r_2 + \theta_2)\sin(r_1 - r_2) + \cos(\theta_2)(r_1 - r_2)) \end{aligned} \right)^2 + \left(\begin{aligned} &4B(\alpha - 1)(1 + \cos(r_2)) - \lambda_1(\cos(2r_2 + \theta_1) + 2\pi \sin(\theta_1) + 2r_2 \sin(\theta_1) - \cos[\theta_1])\lambda_1 + \\ &2(\pi \sin(\theta_2) - \sin(r_2)\sin(r_2 + \theta_2) + r_2 \sin(\theta_2))\lambda_2 \end{aligned} \right)^2} \quad (34)$$

where

$$r_1 = \frac{\text{ArcCos} \left(\frac{B(1 - \alpha)(\lambda_1 \cos(r_1) - \cos(r_2)\lambda_2) + \sqrt{(\sin(\theta_1)\lambda_1 - \sin(\theta_2)\lambda_2)^2 ((B + \alpha B)^2 + \lambda_1^2 - 2\lambda_1\lambda_2 \cos(\theta_1 - \theta_2) + \lambda_2^2)}}{\lambda_1^2 - 2\lambda_1\lambda_2 \cos(\theta_1 - \theta_2) + \lambda_2^2}} \right)}{w} \quad (35)$$

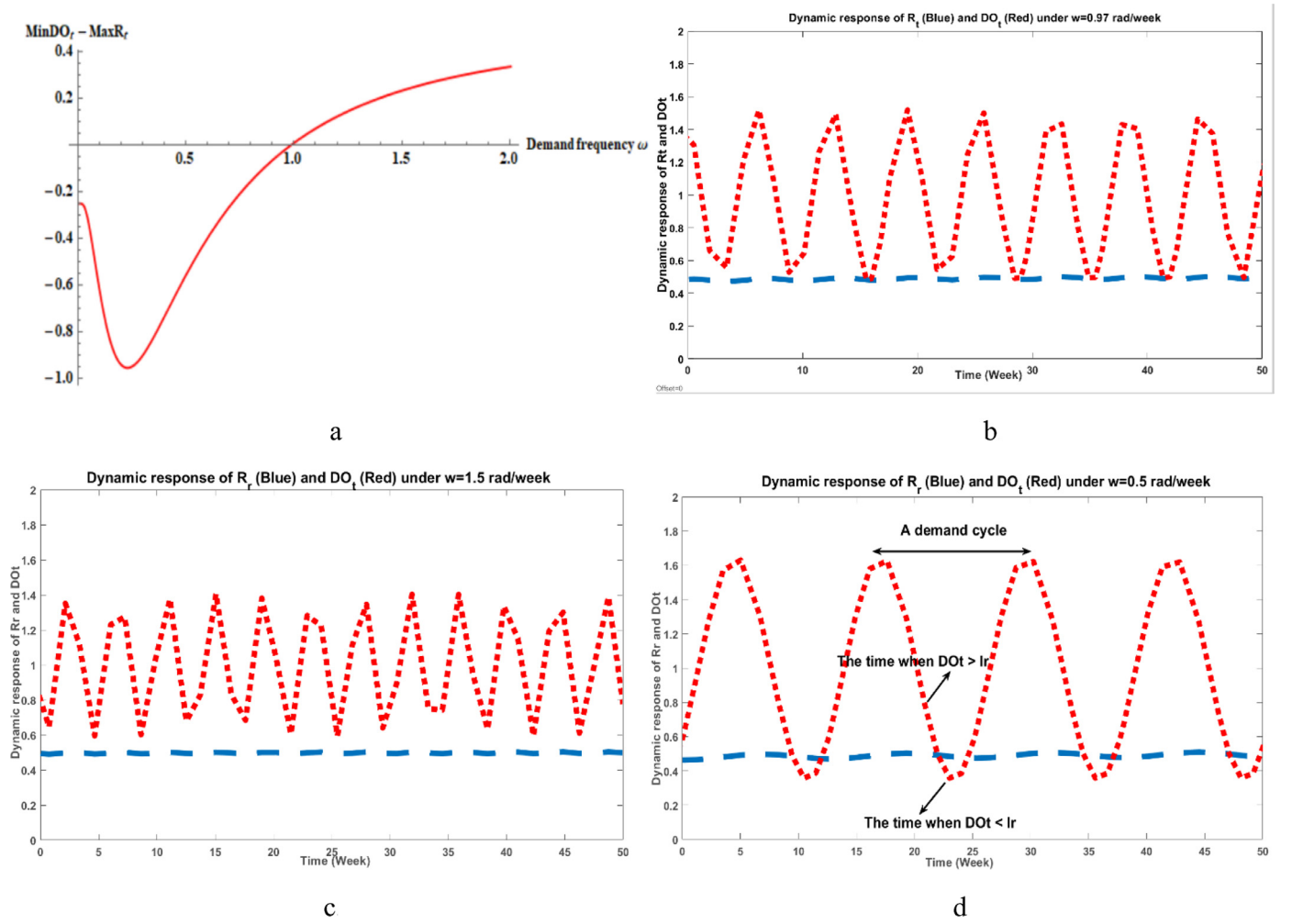

Fig. 3. The plot of $\text{Min}DO_t - \text{Max}R_r$ as the function of ω and the dynamic response of DO_t and R_r under $\text{Min}DO_t - \text{Max}R_r=0$ (Fig. 3b), $\text{Min}DO_t - \text{Max}R_r>0$ (Fig. 3c) and $\text{Min}DO_t - \text{Max}R_r<0$ (Fig. 3d).

$$r_2 = \frac{\text{ArcCos} \left(\frac{B(\alpha - 1)(\lambda_1 \text{Cos}(r_1) - \text{Cos}(r_2)\lambda_2) - \sqrt{(\text{Sin}(\theta_1)\lambda_1 - \text{Sin}(\theta_2)\lambda_2)^2 ((B + \alpha B)^2 + \lambda_1^2 - 2\lambda_1\lambda_2 \text{Cos}(\theta_1 - \theta_2) + \lambda_2^2)}}{\lambda_1^2 - 2\lambda_1\lambda_2 \text{Cos}(\theta_1 - \theta_2) + \lambda_2^2} \right)}{w} \quad (36)$$

$$\lambda_1 = A \sqrt{\frac{1 + (\omega + \omega(\widehat{\tau}_p + \tau_a))^2}{(1 + \omega^2)(1 + \omega^2\tau_a^2)}}, \quad \lambda_2 = \frac{\alpha A}{\sqrt{(1 + \omega^2\tau_c^2)(1 + \omega^2)}} \quad (37)$$

$$\theta_1 = -\tan^{-1} \left(\frac{\omega + \omega\tau_a}{1 - \omega^2\tau_a} \right) + \tan^{-1}(\omega + \omega(\widehat{\tau}_p + \tau_a)), \quad \theta_2 = -\tan^{-1}(\omega\tau_c) - \tan^{-1}(\omega) \quad (38)$$

Proof 5: See Appendix 1.3.
 Given the complex analytical expression of DF gain for O_r and O_m , we plot $DF(O_r)$ and $DF(O_m)$ as a function of demand frequency ($\omega=0.1-1$ rad/week) and demand amplitude ($A=0.1-1$) under high and low return rates, that is, using $\alpha = 0.3$ and $\alpha=0.8$ as shown in

Fig. 4. Note that other system parameter settings are shown below, following Tang & Naim (2004) and Zhou et al. (2017)'s benchmark CLSC models

$$D_c = A \cos(\omega t) + 1, \quad \tau_a = 16, \quad \tau_c = 32, \quad \tau_m = 8, \quad \tau_r = 4$$

Fig. 4a DF gain in relation to demand frequency Fig. 4b. DF gain in relation to demand variance

Based on Fig. 4a, we find that $DF(O_r)$ displays a concave U-shaped relationship with respect to demand frequency, while $DF(O_m)$ shows a convex U-shaped relationship with demand variance. The results highlight the importance of monitoring product demand frequency if a remanufacturing pull-controlled policy is adopted in the hybrid system. For those low or medium demand frequencies, high total order variance may be largely absorbed by remanufacturing production O_r , leading to the bullwhip effect. However, if the product is characterised by high demand frequency,

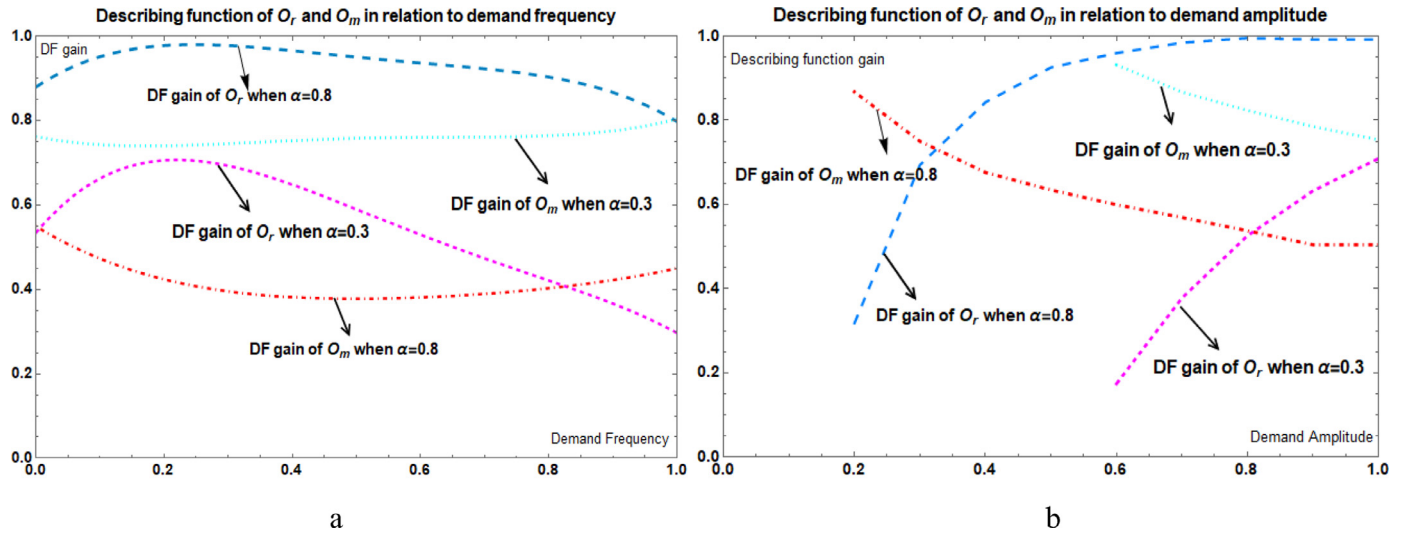

Fig. 4. $DF(O_r)$ and $DF(O_m)$ in relation to demand frequency (4a) and demand variance (4b).

manufacturing production, O_m will take priority in absorbing customer demand.

Also, product return rate plays an important role in influencing the describing function gain in the pull-controlled remanufacturing system. High product return rate significantly increases $DF(O_r)$ comparing with a low return rate. As $OV_{Pull}(O_r)$ and

$OV_{Pull}(O_m)$ can be approximated by $\sqrt{\frac{1+(\omega+\omega(\widehat{\tau}_p+\tau_a))^2}{(1+\omega^2)(1+\omega^2\tau_a^2)}} \cdot DF(O_r)$ and

$\sqrt{\frac{1+(\omega+\omega(\widehat{\tau}_p+\tau_a))^2}{(1+\omega^2)(1+\omega^2\tau_a^2)}} \cdot DF(O_m)$, remanufacturing production may generate high bullwhip if a large proportion of sold products are returned to the hybrid system. This is due to the order allocation policy, i.e. remanufacturing priority, where the high order variance of DO_t generated is increasingly absorbed by remanufacturing production with an increase in returned product rate. However, if the return rate is low, the insufficient recoverable inventory forces the hybrid system to frequently switch to manufacturing production to satisfy DO_t .

Furthermore, demand variance (amplitude) profoundly impacts on $DF(O_r)$ and $DF(O_m)$. With an increase in demand amplitude ($A > 0.2$), the system operates at *State 2* and a further increase in demand amplitude leads to an increase in $DF(O_r)$ and a decrease in $DF(O_m)$. This means increased demand variance can be largely absorbed by remanufacturing production, leading to high bullwhip levels. However, for low demand amplitudes ($0 < A < 0.2$), the pull-controlled hybrid system operates at *State 1*. This is because under *Operating State 1*, the hybrid system with pull-based remanufacturing is similar to the push-based system in which all returned products are pushed into remanufacturing production due to insufficient recoverable inventory. It should be noted that α plays an essential role in influencing the switch from linear remanufacturing push to nonlinear remanufacturing pull. *Operating State 2* occurs at low demand amplitudes (e.g. $0 < A < 0.2$) if α is high (e.g. $\alpha = 0.8$), while for $\alpha = 0.3$, the hybrid system maintains *Operating State 1* when demand amplitude is $0 < A < 0.6$. This suggests that, if a large proportion of sold products are returned, the hybrid system switches to 'pure' remanufacturing pull even if demand variance is low.

Furthermore, demand variance (amplitude) profoundly impacts on $DF(O_r)$ and $DF(O_m)$. With an increase in demand amplitude ($A > 0.2$), the system operates at *State 2* and a further increase in demand amplitude leads to an increase in $DF(O_r)$ and a decrease in $DF(O_m)$. This means increased demand variance can be largely absorbed by remanufacturing production, leading to high bullwhip levels. However, for low demand amplitudes ($0 < A < 0.2$), the pull-controlled hybrid system operates at *State 1*. This is because under *Operating State 1*, the hybrid system with pull-based remanufacturing is similar to the push-based system in which all returned products are pushed into remanufacturing production due to insufficient recoverable inventory. It should be noted that α plays an essential role in influencing the switch from linear remanufacturing push to nonlinear remanufacturing pull. *Operating State 2* occurs at low demand amplitudes (e.g. $0 < A < 0.2$) if α is high (e.g. $\alpha = 0.8$), while for $\alpha = 0.3$, the hybrid system maintains *Operating State 1* when demand amplitude is $0 < A < 0.6$. This suggests that, if a large proportion of sold products are returned, the hybrid system switches to 'pure' remanufacturing pull even if demand variance is low.

5. Simulation analysis

In this section, we further study the hybrid system using the numerical simulation software Matlab®. We verify the analytical

results shown by *Propositions 2 – 5*. Also, we extensively compare the order variance performance of the hybrid system under pull- and push-controlled remanufacturing policies. Finally, we conduct the remanufacturing and manufacturing lead time sensitivity analysis to understand the impact of system production delay variance on bullwhip performance.

5.1. Verification

We verify *Propositions 2–5* by comparing the analytical and simulation results of total order manufacturing order and remanufacturing order variance in both pull and push-controlled hybrid systems, as shown in [Table 2](#). Also, the describing function gain in pull-controlled hybrid system, that is, *Proposition 4*, is verified. We select $\omega = 0.1, 0.5$ and 1 rads/week to represent different types of product characterised by low, medium and high demand frequencies. Also, to ensure the remanufacturing pull-controlled hybrid system maintains *Operating State 1*, demonstrated by *Proposition 4*, we adopt the following system parameter settings:

$$D_c = \cos(\omega t) + 1, \tau_a = 16, \tau_c = 32, \tau_m = 8, \tau_r = 4, \alpha = 0.3$$

In general, our analytical results precisely predict the order variance of total orders, manufacturing and remanufacturing in both pull and push-controlled remanufacturing hybrid systems. Note that for high demand frequency, the analytical prediction is not as precise as with low demand frequency. As illustrated by [Wang et al. \(2015\)](#), this is the main limitation of describing function approximation (i.e. the low-filter property) and hence where simulation is needed for an input of high frequency.

5.2. Bullwhip comparison

We systematically compare order variance of O_r and O_m in relation to product demand frequency (ω), product return rate (α) and product return delay (τ_c). We define $OV_{Push}(O_m)$, $OV_{Push}(O_r)$, $OV_{Pull}(O_r)$ and $OV_{Pull}(O_m)$ as order variance ratio of O_m and O_r under push- and pull-controlled hybrid system in relation to demand variance. Note that the baseline settings follow benchmark model developed by [Tang & Naim \(2004\)](#) and [Zhou et al. \(2017\)](#), although we vary each parameter to assess its impact on order variance, and we choose $\alpha = 0.3$ and 0.8 to represent the low return and high return rate scenarios. Another reason for choosing such baseline settings is to ensure the pull-controlled

Table 2

Simulation verification for analytical prediction. Unbracketed numerical result: Simulation; bracketed numerical result: Analytical prediction. (a). Analytical and simulation results comparison of $OV(DO_t)$, $OV_{Push}(O_r)$ and $OV_{Push}(O_m)$ for push-controlled hybrid system. (b). Analytical and simulation results comparison of $OV_{Push}(O_r)$, $OV_{Push}(O_m)$, $DF(O_r)$ and $DF(O_m)$ for pull-controlled hybrid system.

Demand frequency	Analytical (simulation) results	$OV(DO_t)$	$OV_{Push}(O_r)$	$OV_{Push}(O_m)$
$\omega = 0.1$ rad/week		1.23 (1.32)	0.089 (0.09)	1.15 (1.31)
$\omega = 0.5$ rad/week		1.19 (1.29)	0.018 (0.017)	1.17 (1.26)
$\omega = 1$ rad/week		0.97 (1.02)	0.01 (0.009)	0.96 (1.01)

Demand frequency	Analytical (simulation) results	$OV_{Pull}(O_r)$	$OV_{Pull}(O_m)$	$DF(O_r)$	$DF(O_m)$
$\omega = 0.1$ rad/week		0.82 (0.95)	0.92 (1)	0.67 (0.70)	0.75 (0.74)
$\omega = 0.5$ rad/week		0.70 (0.75)	0.89 (0.95)	0.58 (0.6)	0.74 (0.76)
$\omega = 1$ rad/week		0.21 (0.3)	0.59 (0.8)	0.22 (0.3)	0.61 (0.80)

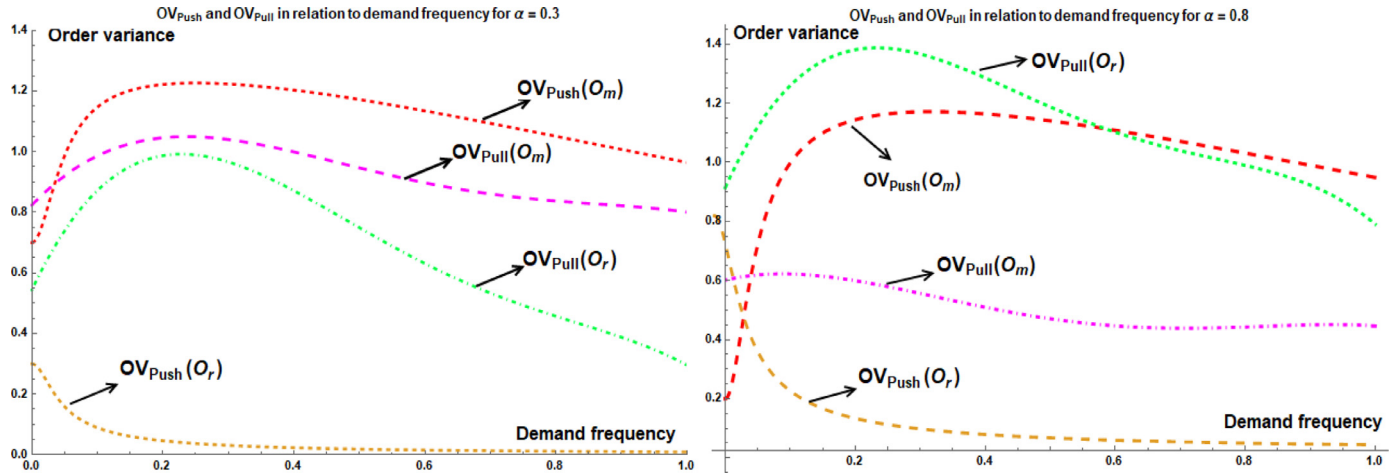

Fig. 5. Order variance of O_r and O_m in relation to ω under $\alpha = 0.3$ and 0.8 .

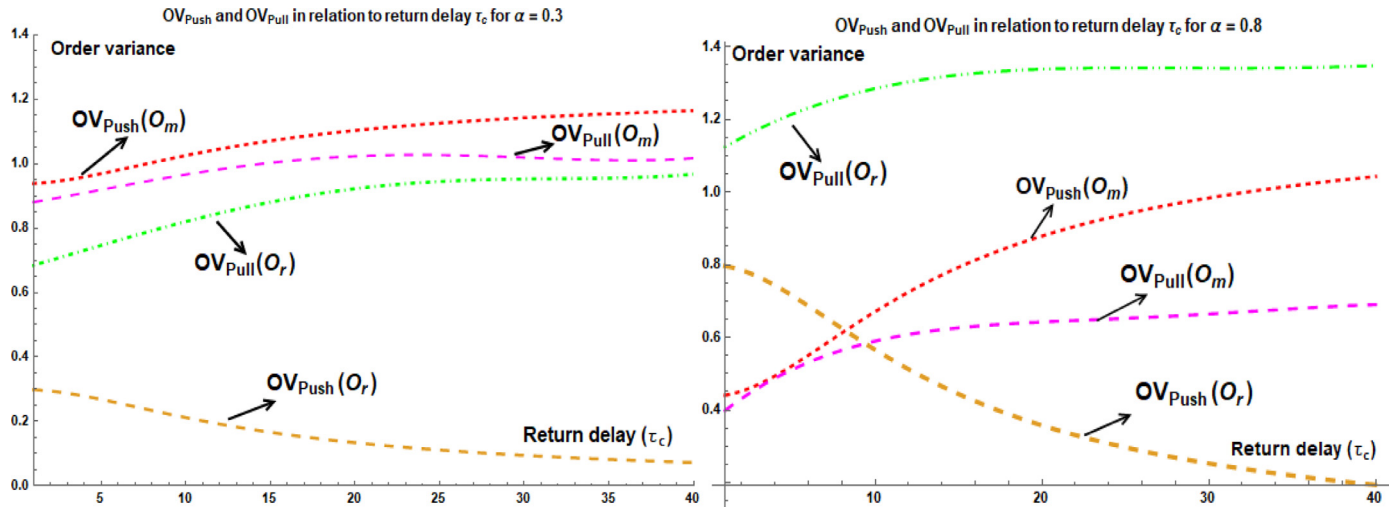

Fig. 6. Order variance of O_r and O_m in relation to τ_c under $\alpha = 0.3$ and 0.8 .

hybrid system operates as *State 1* demonstrated in *Proposition 4*. All results are reported in *Figs. 5 and 6*.

Baseline settings: $\tau_a = 16$, $\tau_m = 8$, $\tau_r = 4$, $\alpha = 0.3$, $\omega = 0.1$ rad/week, $\tau_c = 32$ (Zhou et al., 2017)

Specifically, *Fig. 5* illustrates order variance of O_r and O_m in relation to ω . Overall, $OV_{Push}(O_m)$, $OV_{Pull}(O_r)$ and $OV_{Pull}(O_m)$ display a concave U-shaped relation to demand frequency beside $OV_{Push}(O_r)$, increasing their value as the increase of demand frequency and then decreases as the further increase of demand frequency. The peak of $OV_{Push}(O_m)$, $OV_{Pull}(O_r)$ and $OV_{Pull}(O_m)$ are located around $0.1 - 0.3$ rad/week.

At low return rate, $\alpha = 0.3$, pull-controlled hybrid system generates less bullwhip than the corresponding push-controlled system. $OV_{Pull}(O_m)$ and $OV_{Pull}(O_r)$ are less than 1 for most demand frequencies, although $OV_{Pull}(O_m)$ produces bullwhip around $\omega = 0.19 - 0.3$ rad/week. However, $OV_{Push}(O_m) > 1$ for demand frequency between 0.1 rad/week - 1 rad/week, reaching 1.4 as peak level. Although $OV_{Push}(O_r)$ cannot generate bullwhip, as all returned products are ‘pushed’ into remanufacturing production in push-controlled hybrid system, such a result indicates pull-controlled hybrid system performs better than the push-based hybrid system at low return rates.

When the return rate is increased to $\alpha = 0.8$, $OV_{pull}(O_r)$ is significantly increased and larger than 1 for most of demand frequencies, suggesting bullwhip is induced by remanufacturing production in pull-controlled system. Also, $OV_{pull}(O_r) > OV_{push}(O_r)$ for low and medium demand frequencies (i.e. from 0.1 to 0.6 rad/week), and $OV_{pull}(O_m)$ is always greater than $OV_{push}(O_r)$. This means if the product return rate is high, pull-controlled hybrid system, on the other hand, generates high bullwhip in comparison to the push-based system. This is particularly the case when the demand is characterised by low frequencies.

Also, $OV_{push}(O_m)$ is decreased with an increase in return rate. Given $OV_{push}(O_m) = \alpha \sqrt{\frac{1}{1+\omega^2\tau_c^2}}$, see Proposition 3, and cannot produce bullwhip, we can conclude that the increased return rate alleviates the variability in push-controlled hybrid supply chains. This result is consistent with many push-based remanufacturing dynamics literature, e.g. Tang and Naim (2004) Type 2 and Type 3 Push-based hybrid models; Zhou et al.'s (2006) push hybrid models; Ponte et al. (2020) Model 1 and 2. However, based on the simulation results, the increased return rate plays a significant role in increasing $OV_{pull}(O_r)$, leading to high bullwhip. This implies high return rates can deteriorate the system dynamics performance of the hybrid system if remanufacturing is controlled by a pull policy.

It is also interesting to note that under the pull-controlled remanufacturing policy, $OV_{pull}(O_m)$ is always larger than $OV_{pull}(O_r)$ in low return rate scenarios, while the opposite result can be found in a high return rate situation. This is due to the nature of the pull-controlled remanufacturing policy in the hybrid system such that DO_t is prioritised to the remanufacturing production if there is sufficient I_r . As a result, remanufacturing production absorbs the majority of order variance of DO_t if the product return rate is high. However, O_m and O_r simultaneously produce serviceable inventory to fulfil DO_t for low return rate scenarios due to limited I_r , improving the order variance performance.

Fig. 6 plots the order variance of O_r and O_m in relation to τ_c . Instead of a U-shape relationship between order variance and demand frequency, an increased τ_c leads to the increased $OV_{pull}(O_m)$, $OV_{pull}(O_r)$ and $OV_{push}(O_m)$, although this is not the case for $OV_{push}(O_r)$ due to the nature of the push policy. Such results are consistent with previous literature (Ponte et al., 2019; Zhou et al., 2006, 2017). Similar to the order variance of O_r and O_m in relation to ω , the pull-controlled hybrid system performs better than push-controlled system under low return rate, $\alpha = 0.3$. $OV_{pull}(O_m)$ and $OV_{pull}(O_r)$ are less than 1 for the whole spectrum of return delays, while $OV_{push}(O_m)$ can generate bullwhip with an increase in return delay.

However, the increased product return rate leads to different order variances for O_r and O_m . For the pull-controlled hybrid system, $OV_{pull}(O_r)$ always induces bullwhip regardless of return delay, while τ_c plays little impact on $OV_{pull}(O_m)$. Regarding the push-based hybrid system, $OV_{push}(O_r)$ can be significantly reduced with an increase in τ_c at the expense of increasing $OV_{push}(O_m)$, and thus leads to bullwhip. Note that the impact of τ_c on order variance of push-controlled hybrid system under high return rate is significantly higher than the corresponding low return rate scenario. When $\alpha = 0.8$, the increase of τ_c significantly increase $OV_{push}(O_m)$, while significantly decrease $OV_{push}(O_r)$. However, this is not the case for $\alpha = 0.3$.

We can conclude that return rate significantly influences bullwhip effect of the hybrid system controlled with both push and pull remanufacturing policies. If product return rate is low, the pull-based system outperforms the corresponding push-based hybrid system in which order variance of DO_t can be allocated to both O_r and O_m . However, with an increase in return rate, O_r is responsible for satisfying a majority of DO_t under

the remanufacturing priority policy, causing high bullwhip levels.

5.3. Lead time analysis

Recall Proposition 1 that the permanent inventory drift can be eliminated by appropriately estimating $\hat{\tau}_p$. In order to assess the impact of τ_m and τ_r on bullwhip performance of the two different hybrid systems, we plot OV_{push} and OV_{pull} (Fig. 7) by varying τ_m and τ_r , while other system settings remain the same indicated in baseline settings.

Overall, τ_m and τ_r positively impact on $OV_{push}(O_m)$, $OV_{pull}(O_r)$ and $OV_{pull}(O_m)$. $OV_{push}(O_r)$, however, is not influenced by manufacturing and remanufacturing delays, as the timing for push remanufacturing is only determined by return delay in a push-controlled hybrid system. Another finding is that the strength of manufacturing lead times on bullwhip is higher than the corresponding impact of remanufacturing lead times. For example, $OV_{push}(O_m) = 1.55$, $OV_{pull}(O_r) = 1.5$, $OV_{pull}(O_m) = 1.25$ for $\tau_m = 20$, while $OV_{push}(O_m) = 1.4$, $OV_{pull}(O_r) = 1.3$, $OV_{pull}(O_m) = 1.15$ for $\tau_r = 20$. As analysed in Proposition 1, this is due to $\hat{\tau}_p = \tau_m(1 - \alpha) + \alpha\tau_r$. If the return yield is low, i.e. $\alpha < 0.5$, τ_m plays a more important role in influencing $\hat{\tau}_p$ than τ_r and vice versa. As derived and analysed in Proposition 2, this highlights the importance of exploring product demand characteristics to improve system dynamics performance of a hybrid system. Given remanufacturing lead times are usually shorter than manufacturing productions (Zhou et al., 2017), if the product return yield rate is relatively low, the reduction of manufacturing lead times is an effective strategy in directly reducing bullwhip. However, if most of sold products are expected to be returned, e.g. military photonics (Goltsov et al., 2019), the incentive for remanufacturing reduction investment may become too high.

5.4. Summary

We summarize all main findings and results based on analytical and simulation conducted in Sections 4 and 5. Specifically, for DO_t , it remains the same in both push and pull controlled remanufacturing production, although bullwhip in DO_t increases with $\hat{\tau}_p$, and also with increases in τ_m and τ_r under the adapted $\hat{\tau}_p$ scenario, i.e. $\hat{\tau}_p = \tau_m(1 - \alpha) + \alpha\tau_r$. Furthermore, if $\alpha < 0.5$, bullwhip in DO_t is more significantly associated with τ_m than with τ_r .

For Push-controlled remanufacturing production, it can be concluded that $OV_{push}(O_m) < 1$ regardless of ω and τ_c and an increase in α leads to a decrease in $OV_{push}(O_m)$. On the other hand, the hybrid CLSC system characterised by **Pull-controlled remanufacturing production** may switch between two different operating states, *Operating States 1 and 2*. The system performs similarly to the push-controlled remanufacturing in *Operating State 1*, while the hybrid system operates at *Operating State 2* for high demand variance, low demand frequency and low return rate. Furthermore, based on the describing function analysis, DF gain presents a U-shape in relation to demand frequency in pull-controlled remanufacturing environment and $DF(O_r)$ increases with respect to return rate, while $DF(O_m)$ decreases with an increase return rate

By comparing bullwhip under push and pull-controlled remanufacturing production, we can conclude that return rate, α , plays a dominant role in influencing the choice of push or pull-controlled hybrid system, given the pull-controlled system operates at *State 2*. Also, compared to α , τ_r plays a supplementary role in order variance of manufacturing and remanufacturing, order rates. An increase in τ_r leads to an increase in $OV_{pull}(O_m)$, $OV_{push}(O_m)$ and $OV_{push}(O_m)$, but an decrease in $OV_{push}(O_r)$. Finally, $OV_{push}(O_m)$, $OV_{pull}(O_r)$ and $OV_{pull}(O_m)$ present a concave U-shaped relationship to demand frequency.

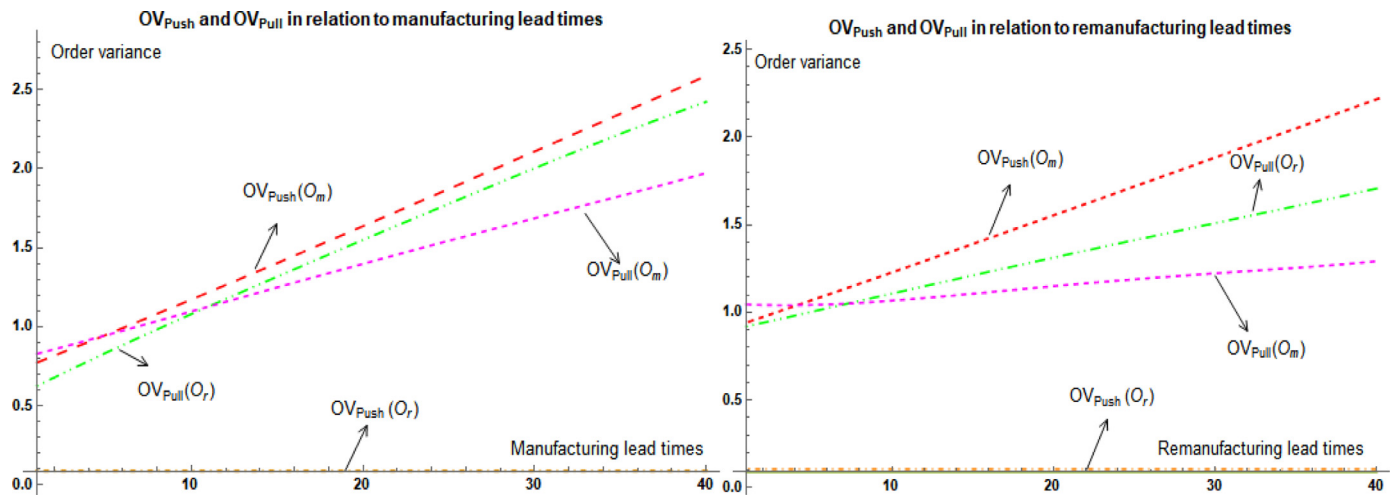

Fig. 7. Order variance of O_r and O_m in relation to τ_m and τ_r when $\alpha = 0.3$.

Based on above analytical and simulation results, we derive the following managerial implications:

- 1 Overall, lead time reduction for both manufacturing and remanufacturing is a way in reducing bullwhip, and thus, reducing operational costs. Particularly, if the product return yield rate is relatively low, the reduction of manufacturing lead times is an effective strategy in directly reducing bullwhip. Depending on different industries, if the product return rate is expected to be low, more investment in lead time reduction should be given to manufacturing processes. However, if we expect a high return rate, reducing remanufacturing lead times, including the opportunities of reducing disassembly, quality test and remanufacturing production, leads to reduced operational costs.
- 2 Remanufacturing cannot produce bullwhip in the push-based scenario. Also, encouraging product returns can benefit from improved system dynamics performance by reducing bullwhip levels in the manufacturing process.
- 3 If the product demand variance is low, there is no difference between push and pull-controlled hybrid system in dynamic performance. The hybrid system with remanufacturing push is recommended if **high product return rate** can be achieved ($\alpha > 0.5$). Under such a situation, the overall bullwhip level can be effectively reduced by shorting the return delay. For example, this may be achieved by increasing the effectiveness of the collection process and giving incentives for customer to return their used products. The hybrid system with remanufacturing pull policy is recommended if **the product return rate is low and demand variance is high**. The reduction of return delay, similarly, can adequately improve the system dynamics performance in such a case.
- 4 It is important to determine product demand frequencies and group the products with the same characteristics, as demand frequency significantly impacts on bullwhip in both manufacturing and remanufacturing process for both push and pull-based systems.

6. Conclusion

We developed a nonlinear system dynamics model of the hybrid CLSC system, capturing characteristics of remanufacturing push and pull production. Using linear and non-linear control techniques, we derived analytical results for bullwhip, showing the impact of inherent system structure (physical lead times, feedback loops, policies and forecasting) as well as product demand char-

acteristics (demand frequency, return rate and return delay) on the bullwhip effect. We systematically compared bullwhip performance for push and pull-controlled remanufacturing production and extensive numerical simulation is conducted to verify the analytical results.

We found product return rate is the key parameter in influencing bullwhip performance of a pull-controlled hybrid system. Product demand frequency is another important factor for system dynamics performance of the hybrid system. Given order variance has a concave U-shaped relation to demand frequency, production managers may need to carefully consider their product demand frequency to avoid high bullwhip effect. Moreover, product return delay shows a supplementary impact on system dynamics. The traditional push-controlled hybrid system may be significantly influenced by return delay if the return rate is high.

We contribute to the bullwhip effect analysis for two remanufacturing production control policies. We analytically approximate the bullwhip level under pull-controlled remanufacturing, in which the recoverable inventory constraint is characterised by multi-valued nonlinearity properties. We focus on bullwhip analysis using the frequency analysis method, considering the transform between the time and frequency domains. This can help practitioners to carefully think about the impact of their customer demand characteristics and their system structure for the bullwhip avoidance or reduction.

Regarding future research directions, the incorporation of a forbidden return nonlinearity and analysis of the impact of other types of nonlinearities on the bullwhip effect can be considered. Also, given many practical hybrid systems' limited production capacity, the in-depth investigation of capacity constraints together with recoverable inventory constraints should be considered. Finally, given our study is an initial exploration of system dynamics for such push / pull hybrid systems, a cost function can be developed and relevant optimization studies can be considered by incorporating order variance and inventory variance related costs including holding and stockout costs.

Acknowledgment

This research was supported by UK's Engineering and Physical Sciences Research Council (EPSRC) under the project Resilient Remanufacturing Networks: Forecasting, Informatics and Holons (EP/P008925/1). This research was also supported by the [National Natural Science Foundation of China](#) (NSFC) under the Grant [72001176](#) and Xi'an Jiaotong-Liverpool University Research Devel-

opment Fund under the Grant RDF-19-01-03. Finally, we are very grateful for the valuable and constructive comments received from the Editorial Team of this journal and three anonymous reviewers.

Supplementary materials

Supplementary material associated with this article can be found, in the online version, at doi:10.1016/j.ejor.2021.10.031.

References

- Atasu, A., Toktay, L. B., & Van Wassenhove, L. N. (2013). How collection cost structure drives a manufacturer's reverse channel choice. *Production and Operations Management*, 22, 1089–1102.
- Bendoly, E., Swink, M., & Simpson III, W. P. (2014). Prioritizing and monitoring concurrent project work: Effects on switching behavior. *Production and Operations Management*, 23(5), 847–860.
- Cachon, G. P., Randall, T., & Schmidt, G. M. (2007). In search of the bullwhip effect. *Manufacturing & Service Operations Management*, 9(4), 457–479.
- Cannella, S., Di Mauro, C., Dominguez, R., Ancarani, A., & Schupp, F. (2019). An exploratory study of risk aversion in supply chain dynamics via human experiment and agent-based simulation. *International Journal of Production Research*, 57(4), 985–999.
- Costas, J., Ponte, B., de la Fuente, D., Pino, R., & Puche, J. (2015). Applying Goldratt's theory of constraints to reduce the bullwhip effect through agent-based modeling. *Expert Systems with Applications*, 42(4), 2049–2060.
- Crosun, R., Donohue, K., Katok, E., & Sterman, J. (2014). Order stability in supply chains: Coordination risk and the role of coordination stock. *Production and Operations Management*, 23(2), 176–196.
- Dejonckheere, J., Disney, S. M., Lambrecht, M. R., & Towill, D. R. (2003). Measuring and avoiding the bullwhip effect: A control theoretic approach. *European Journal of Operational Research*, 147(3), 567–590.
- Dejonckheere, J., Disney, S. M., Lambrecht, M. R., & Towill, D. R. (2002). Transfer function analysis of forecasting induced bullwhip in supply chains. *International Journal of Production Economics*, 78(2), 133–144.
- Dev, N. K., Shankar, R., & Choudhary, A. (2017). Strategic design for inventory and production planning in closed-loop hybrid systems. *International Journal of Production Economics*, 183, 345–353.
- Disney, S. M., & Towill, D. R. (2005). Eliminating drift in inventory and order based production control systems. *International Journal of Production Economics*, 93, 331–344.
- Dominguez, R., Ponte, B., Cannella, S., & Framinan, J. M. (2019). On the dynamics of closed-loop supply chains with capacity constraints. *Computers & Industrial Engineering*, 128, 91–103.
- European Remanufacturing Network (2015). "Remanufacturing Market Study." Accessed 12 July 2021 <http://www.remanufacturing.org.uk/pdf/story/727crr1.pdf>.
- Georgiadis, P., Vlachos, D., & Tagaras, G. (2006). The impact of product lifecycle on capacity planning of closed-loop supply chains with remanufacturing. *Production and Operations Management*, 15(4), 514–527.
- Goltsos, T. E., Ponte, B., Wang, S., Liu, Y., Naim, M. M., & Syntetos, A. A. (2019). The boomerang returns? Accounting for the impact of uncertainties on the dynamics of remanufacturing systems. *International Journal of Production Research*, 57(23), 7361–7394.
- Größler, A., Thun, J. H., & Milling, P. M. (2008). System dynamics as a structural theory in operations management. *Production and operations management*, 17(3), 373–384.
- Guide Jr, V. D. R., & Van Wassenhove, L. N. (2009). OR FORUM—The evolution of closed-loop supply chain research. *Operations Research*, 57(1), 10–18.
- Hosoda, T., Disney, S. M., & Gavirneni, S. (2015). The impact of information sharing, random yield, correlation, and lead times in closed loop supply chains. *European Journal of Operational Research*, 246(3), 827–836.
- Hosoda, T., Disney, S. M., & Zhou, L. (2021). The yield rate paradox in closed-loop supply chains. *International Journal of Production Economics*, Article 108187.
- Hosoda, T., & Disney, S. M. (2018). A unified theory of the dynamics of closed-loop supply chains. *European Journal of Operational Research*, 269(1), 313–326.
- Jakšič, M., & Rusjan, B. (2008). The effect of replenishment policies on the bullwhip effect: A transfer function approach. *European Journal of Operational Research*, 184(3), 946–961.
- Jonkman, J., Barbosa-Póvoa, A. P., & Bloemhof, J. M. (2019). Integrating harvesting decisions in the design of agro-food supply chains. *European Journal of Operational Research*, 276(1), 247–258.
- Karabuk, Suleyman, & Wu, S. David (2003). Coordinating Strategic Capacity Planning in the Semiconductor Industry. *Operations Research*, 51(6), 839–849.
- Lee, Hau L., & Tang, Christopher S. (1997). Modelling the costs and benefits of delayed product differentiation. *Management Science*, 43(1), 40–53.
- Li, J. C., Zhou, Y. W., & Huang, W. (2017). Production and procurement strategies for seasonal product supply chain under yield uncertainty with commitment-option contracts. *International Journal of Production Economics*, 183, 208–222.
- Lin, J., Naim, M. M., & Spiegler, V. L. (2020). Delivery time dynamics in an assemble-to-order inventory and order based production control system. *International Journal of Production Economics*, 223, Article 107531.
- Lin, J., & Naim, M. M. (2019). Why do nonlinearities matter? The repercussions of linear assumptions on the dynamic behaviour of assemble-to-order systems. *International Journal of Production Research*, 57(20), 6424–6451.
- Lin, J., Naim, Mohamed M., Purvis, Laura, & Gosling, Jonathan (2017). The Extension and Exploitation of the inventory and order based production control system archetype from 1982 to 2015. *International Journal of Production Economics*, 194, 135–152.
- Lin, J., Spiegler, V. L., & Naim, M. M. (2018). Dynamic analysis and design of a semiconductor supply chain: A control engineering approach. *International Journal of Production Research*, 56(13), 4585–4611.
- Moritz, B., Siemsen, E., & Kremer, M. (2014). Judgmental forecasting: Cognitive reflection and decision speed. *Production and Operations Management*, 23(7), 1146–1160.
- Nichols, W., 2014. How HP is closing the loop on cartridge recycling, available at: <http://www.businessgreen.com/bg/analysis/2343266/how-hp-is-closing-the-loop-on-cartridge-recycling>.
- Ponte, B., Framinan, J. M., Cannella, S., & Dominguez, R. (2020). Quantifying the Bullwhip Effect in closed-loop supply chains: The interplay of information transparencies, return rates, and lead times. *International Journal of Production Economics*, Article 107798.
- Ponte, B., Naim, M. M., & Syntetos, A. A. (2019). The value of regulating returns for enhancing the dynamic behaviour of hybrid manufacturing-remanufacturing systems. *European Journal of Operational Research*, 278(2), 629–645.
- Savaskan, R. C., Bhattacharya, S., & Van Wassenhove, L. N. (2004). Closed-loop supply chain models with product remanufacturing. *Management Science*, 50, 239–252.
- Spiegler, V. L., & Naim, M. M. (2017). Investigating sustained oscillations in nonlinear production and inventory control models. *European Journal of Operational Research*, 261(2), 572–583.
- Spiegler, V. L., Naim, M. M., Towill, D. R., & Wikner, J. (2016). A technique to develop simplified and linearised models of complex dynamic supply chain systems. *European Journal of Operational Research*, 251(3), 888–903.
- Springer, M., & Kim, I. (2010). Managing the order pipeline to reduce supply chain volatility. *European Journal of Operational Research*, 203(2), 380–392.
- Sterman, J., Oliva, R., Linderman, K. W., & Bendoly, E. (2015). System dynamics perspectives and modeling opportunities for research in operations management. *Journal of Operations Management*, 39, 40.
- Suntory, 2019. Suntory group sustainability site. <https://www.suntory.com/csr/data/report/pdf/suntorycsr2019allEN.pdf>.
- Tang, O., & Naim, M. M. (2004). The impact of information transparency on the dynamic behaviour of a hybrid manufacturing/remanufacturing system. *International Journal of Production Research*, 42(19), 4135–4152.
- Towill, D. R., Zhou, L., & Disney, S. M. (2007). Reducing the bullwhip effect: Looking through the appropriate lens. *International Journal of Production Economics*, 108(1–2), 444–453.
- Turrisi, M., Bruccoleri, M., & Cannella, S. (2013). Impact of reverse logistics on supply chain performance. *International Journal of Physical Distribution & Logistics Management*, 43(7), 564–585.
- Udenio, M., Vatamidou, E., Fransoo, J. C., & Dellaert, N. (2017). Behavioral causes of the bullwhip effect: An analysis using linear control theory. *IIEE Transactions*, 49(10), 980–1000.
- Van der Laan, E. A., & Teunter, R. H. (2006). Simple heuristics for push and pull remanufacturing policies. *European Journal of Operational Research*, 175(2), 1084–1102.
- Van Der Laan, E., Salomon, M., Dekker, R., & Van Wassenhove, L. (1999). Inventory control in hybrid systems with remanufacturing. *Management Science*, 45(5), 733–747.
- Vander Velde, W. E. (1968). *Multiple-input describing functions and nonlinear system design*. New York: McGraw-Hill.
- Wang, X., & Disney, S. M. (2016). The bullwhip effect: Progress, trends and directions. *European Journal of Operational Research*, 250(3), 691–701.
- Wang, Z., Wang, X., & Ouyang, Y. (2015). Bounded growth of the bullwhip effect under a class of nonlinear ordering policies. *European Journal of Operational Research*, 247(1), 72–82.
- Weinhardt, J. M., Hendijani, R., Harman, J. L., Steel, P., & Gonzalez, C. (2015). How analytic reasoning style and global thinking relate to understanding stocks and flows. *Journal of Operations Management*, 39, 23–30.
- Wu, D. Y., & Katok, E. (2006). Learning, communication, and the bullwhip effect. *Journal of Operations Management*, 24(6), 839–850.
- Zhou, L., & Disney, S. M. (2006). Bullwhip and inventory variance in a closed loop supply chain. *OR Spectrum*, 28(1), 127–149.
- Zhou, L., Naim, M. M., & Disney, S. M. (2017). The impact of product returns and remanufacturing uncertainties on the dynamic performance of a multi-echelon closed-loop supply chain. *International Journal of Production Economics*, 183, 487–502.
- Zhou, L., Naim, M. M., Tang, O., & Towill, D. R. (2006). Dynamic performance of a hybrid inventory system with a Kanban policy in remanufacturing process. *Omega*, 34(6), 585–598.