



- (51) International Patent Classification:
B29D 11/00 (2006.01) *G02C 7/04* (2006.01)
- (21) International Application Number:
PCT/GB2017/050793
- (22) International Filing Date:
21 March 2017 (21.03.2017)
- (25) Filing Language: English
- (26) Publication Language: English
- (30) Priority Data:
1604846.4 22 March 2016 (22.03.2016) GB
- (71) Applicant: CONTACT LENS PRECISION LABORATORIES LTD [GB/GB]; Commerce Way, Leighton Buzzard, Bedford Bedfordshire LU7 4RW (GB).
- (72) Inventors: ABASS, Ahmed; 102 Buckingham Road, Aylesbury Buckinghamshire HP19 9QG (GB). CLAMP, John; 67 Grantchester Street, Cambridge Cambridgeshire CB 9HZ (GB). TURNER, Simon; 36 Town Bridge Mill, Leighton Road, Leighton Buzzard Bedfordshire LU7 1LE (GB). WHITE, Lynn; 4 James Villa, Gilbert Mews, Leighton Buzzard, Bedford Bedfordshire LU7 1NG (GB).

(74) Agents: LIPSCOMBE, Martin et al.; Nash Matthews LLP, 24 Hills Road, Cambridge Cambridgeshire CB2 1JP (GB).

(81) Designated States (unless otherwise indicated, for every kind of national protection available): AE, AG, AL, AM, AO, AT, AU, AZ, BA, BB, BG, BH, BN, BR, BW, BY, BZ, CA, CH, CL, CN, CO, CR, CU, CZ, DE, DJ, DK, DM, DO, DZ, EC, EE, EG, ES, FI, GB, GD, GE, GH, GM, GT, HN, HR, HU, ID, IL, IN, IR, IS, JP, KE, KG, KH, KN, KP, KR, KW, KZ, LA, LC, LK, LR, LS, LU, LY, MA, MD, ME, MG, MK, MN, MW, MX, MY, MZ, NA, NG, NI, NO, NZ, OM, PA, PE, PG, PH, PL, PT, QA, RO, RS, RU, RW, SA, SC, SD, SE, SG, SK, SL, SM, ST, SV, SY, TH, TJ, TM, TN, TR, TT, TZ, UA, UG, US, UZ, VC, VN, ZA, ZM, ZW.

(84) Designated States (unless otherwise indicated, for every kind of regional protection available): ARIPO (BW, GH, GM, KE, LR, LS, MW, MZ, NA, RW, SD, SL, ST, SZ, TZ, UG, ZM, ZW), Eurasian (AM, AZ, BY, KG, KZ, RU, TJ, TM), European (AL, AT, BE, BG, CH, CY, CZ, DE, DK, EE, ES, FI, FR, GB, GR, HR, HU, IE, IS, IT, LT, LU, LV, MC, MK, MT, NL, NO, PL, PT, RO, RS, SE, SI, SK, SM, TR), OAPI (BF, BJ, CF, CG, CI, CM, GA, GN, GQ, GW, KM, ML, MR, NE, SN, TD, TG).

[Continued on next page]

(54) Title: IMPROVEMENTS IN OR RELATING TO CONTACT LENSES

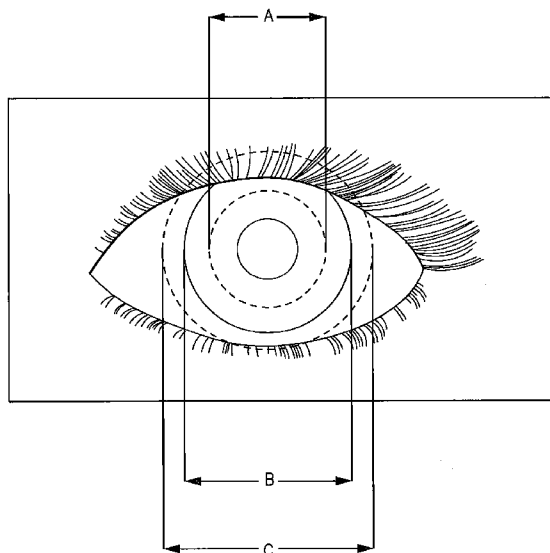

FIG. 1a

(57) Abstract: Disclosed is a contact lens the back surface of which has a shape such that the sagittal depth of a vertical meridian in the non-central surface differs from, and preferably is greater than, the sagittal depth of a vertical meridian in the non-central surface by an amount in the range 50µm to 500µm.



Published:

— with international search report (Art. 21(3))

— before the expiration of the time limit for amending the claims and to be republished in the event of receipt of amendments (Rule 48.2(h))

Title: Improvements in or Relating to Contact Lenses**Field of the Invention**

The present invention relates to a novel contact lens and to novel methods of designing and manufacturing a contact lens for a subject, especially a soft contact lens, and more especially (but not necessarily) a toric soft lens.

Background of the Invention

It is known to manufacture “rigid” contact lenses from materials such as poly methyl methacrylate (PMMA) and related polymers. These lenses are typically about 8-10mm in diameter. Such rigid lenses maintain essentially the same shape whether “on eye” or “off eye”. Some people find rigid lenses uncomfortable and/or difficult to wear and, at least partly as a result, ‘soft’ contact lenses were developed. These are usually made of materials such as hydrogels, especially silicone hydrogels (sometimes referred to as SiH). Soft lenses at least partly conform to the shape of the wearer’s eye, and so have different shapes when on eye and off eye. Soft contact lenses are generally larger than rigid contact lenses, and typically have a diameter in the range 13.5-15.0mm. As such, soft contact lenses usually contact a wider part of the surface of the wearer’s eye than do rigid contact lenses. In particular, soft contact lenses usually contact all or the majority of the corneo-scleral junction or limbus – this is where the tissue in the eye transitions from the cornea (transparent) to the sclera (opaque white tissue). As the eye does not have any obvious external anatomical indicators of the location of the limbus, it is difficult to define the position of the limbus accurately. Accordingly, for practical purposes the limbus is taken as being annular and as having a diameter identical to that of the iris, as viewed externally through the cornea. This dimension is commonly called the “Horizontal Visible Iris Diameter” (HVID). A typical measurement for the HVID in a normal eye is about 11.5mm. A soft contact lens typically has a diameter about 2.0-3.5mm greater than a subject’s HVID.

The anterior ocular surface (“AOS”) of the eye includes all the cornea and those parts of the sclera which are visible when the eye is looking straight ahead and the subject’s eyelids are manually opened to their fullest extent.

The central part of the cornea is described as the central zone, which is a circle of about 6mm in diameter. That part of the anterior surface of the eye which is peripheral to the central zone, but within the AOS, may be defined as the non-central anterior ocular surface, or NCAOS.

It is known to design contact lenses which have a back surface (i.e. the surface of the lens which, in use, is closer to the subject's cornea) which is generally substantially spherical, and a front surface (i.e. that surface of the lens which, in use, is further from the subject's cornea) which has a profile so as generally to confer on the lens optical characteristics which ameliorate a defect in the subject's vision. The radius of curvature of the substantially spherical back surface is said to be the "base curve".

Contact lens manufacturers usually make lenses with a substantially spherical back surface which is one of a defined range or set of back surfaces, the back surface being typically defined, at least in part, by its radius of curvature. Normal values of the radius of curvature of the back surface or base curve of a lathe-cut soft contact lens are in the range 7.80 to 9.00 mm (for moulded lenses, the normal range is about 8.40 to 8.80mm). Typically manufacturers produce a range of lenses with a 0.2mm increment in the radius of curvature, this being referred to as a "step" up or down. The smaller the radius of curvature, the more steeply curved is the back of the lens.

The front surface may be generally spherical (but with a different radius of curvature to that of the back surface, so as to confer a desired optical power on the lens), or may be aspherical. Aspherical contact lenses may be used when a multi-focal lens is required, or to correct particular vision defects such as astigmatism, in which case a lens with a toric front surface is employed.

Where contact lenses are substantially rotationally asymmetric (such as with toric lenses) and thus have a particular desired orientation on eye in order to achieve the necessary vision correction, it is known to add a stabilising means to the front surface of the lens. Conventionally this takes the form of one or more "ballast" zones, or areas of thickening, which interact with one or both eye lids when the eye is

momentarily closed during blinking, which interaction, if the lens is not in the desired orientation, imparts a rotational force on the lens to return it to the desired orientation.

5 Whilst such ‘ballast’ zones are effective in positioning the contact lens in the desired orientation, they suffer from a number of defects. As they are relatively thick, they impede the diffusion of oxygen to the cornea, and also add to the physical discomfort of wearing the lens. Prismatic or other “ballast” designs can also induce a gravitational effect i.e. the weight of the thicker part of the lens can be detrimental when the subject orientates their head to one side (e.g. as when reading whilst lying
10 on a bed or a sofa) as it pulls the lens away from its desired orientation.

In the contact lens industry, assumptions are made about the manner in which a soft contact lens fits to the cornea. As soft lenses are flexible, it is not necessary for the back surface of the lens to align exactly with the front surface of the cornea. Usually,
15 the base curve and diameter of the contact lens is derived from “rules” calculated from measurements of the eye.

Conventionally, the selection of the radius of curvature for the base curve relies on measurement of the central radius of curvature of the cornea using a keratometer (an
20 instrument that measures the radii of curvature of a cornea within a central 4mm zone). This measurement is called a “K-reading” and if it is obtained from another instrument, such as a corneal topography machine, the measurement is referred to as “Sim-K” (i.e. simulated Keratometer).

25 Typically, for the majority of normal eyes, the base curve of a soft lens is set to be 0.8mm flatter than the flattest K reading, (that is, to have a radius of curvature 0.8mm greater than the K reading).

The diameter of the lens is generally based on the Horizontal Iris Visible Diameter
30 (HVID) and is typically set to be around 2.5 to 3mm larger than this measurement.

Disposable contact lenses are very thin and flexible and drape easily over the cornea. Thus, lens dimensions tend to be fixed at static values that are assumed to fit the

widest possible range of corneas. For example, many disposables are set at 8.60:14.40, where 8.60mm is the base curve and 14.40mm is the diameter of the lens. Typically, these parameters will have been validated in clinical trials on a statistically significant number of subjects.

5

Lathe cut customised contact lenses tend to be thicker and more complex in design. Although some types are fitted using trial sets, many laboratories apply "Fitting Rules". These are derived from on eye trials and apply more complex calculations to the K Readings and HVID supplied by the practitioner.

10

For fitting rules to work successfully, certain assumptions are made, including:
the shape of the whole cornea can be predicted from the K reading measurement (central 4mm zone) with reasonable accuracy;
using the K readings as a guide, the periphery of the lens can be predicted to fit the sclera beyond the boundary of the limbus; and
the predictions hold true for both right and left eyes, male and female genders and across all ethnic groups.

15

Contact lenses are trialled using subjects that tend to be in the same geographical area as the company actively designing the lens. Thus, any modifications to that design are based on the characteristics of the test group subjects in that geographical area.

20

Due to the large number of lens designs available, fit issues can often be overcome by changing lens design or using customised designs.

25

It has been possible for many years for ophthalmic practitioners to determine the curvature of a subject's corneal surface over the central optic zone (i.e. that part of the cornea in front of the pupil and the iris, a circular zone of about 8mm in diameter) using a device known as a corneal topographer. Recently, the fall in the cost of the equipment has meant that corneal topography has become used far more widely.

30

Moreover, in the last few years, eye surface profilers have become available. These devices are able to provide data on the curvature of the surface of the cornea over a

much larger portion of the subject's eye (i.e. the anterior ocular surface), covering all of the cornea, the corneo-scleral junction, and a considerable part of the sclera. However, eye surface profiler apparatus is not yet widely used.

5 In a conventional contact lens, circular central portions of the front and/or rear surfaces of the contact lens are responsible for correcting the vision defect of the subject. In most lenses, the vision correction is achieved solely by the curvature of the central portion of the front surface of the lens, but in some lenses the curvature of the central portions of the rear and front surfaces combine to correct the vision defect.

10

The front optical surface of a conventional contact lens (i.e. that portion which is involved in creating the necessary optical power of the lens to correct the subject's vision defect) is a central circular portion of typically 6 to 12mm in diameter. The rear optical surface of a conventional contact lens is a central circular portion with a diameter in the range 7-14mm, more usually 9-13mm, and most typically 10-12mm. The non-central rear surface of a contact lens is thus herein defined as that part of the rear surface which is peripheral to the rear optical surface. Accordingly, in most embodiments the non-central rear surface of the lens will be that part of the rear surface which excludes the central 9-12mm diameter circle. More preferably it will exclude a circular central portion with at least a 10mm diameter, 11mm or 12mm diameter.

15 In addition to any role in correcting the vision defect of the subject, the shape of the rear surface of the contact lens is also important in determining the fit of the lens to the front of the subject's eye, which must be neither too tight nor too loose. The fitting of the lens is largely adjusted by adjusting the curvature of the rear surface of the lens in the non-central portion.

Summary of the Invention

30 In a first aspect, the invention provides a contact lens the back surface of which has a shape such that the sagittal depth of a vertical meridian in the non-central rear surface differs from the sagittal depth of a horizontal meridian in the non-central rear surface

by an amount in the range 50µm to 500 µm, (the non-central rear surface being as defined above).

The sagittal depth of the vertical meridian may be less than that of the sagittal depth of the horizontal meridian by an amount in this range, but more preferably the sagittal depth of the vertical meridian will be greater than the sagittal depth of the horizontal meridian by an amount in this range, as explained below.

The central rear optical surface of the contact lens is preferably an aspheric surface or toroidal aspheric surface having the definition as follows:

$$Z = (X^2 / R_x + Y^2 / R_y) / (1 + \sqrt{1 - (P_x X^2) / R_x^2 - (P_y Y^2) / R_y^2})$$

where:

Z is the sagittal depth of the optical surface for a given X and Y (X and Y being orthogonal axes; the horizontal and vertical meridians respectively) R_x and R_y are the radii in the respective directions X and Y; and P_x and P_y are the conic section P values in the respective directions X and Y (P being a measure of the eccentricity of the conic section).

R and P values are dependent on the central K readings of the cornea to be fitted and values are well known to persons skilled in the art of contact lens design.

The overall size of the rear central optical surface is a circle with a diameter normally in the range 7mm to 14mm; preferably 9mm to 13mm; more preferably 10mm to 12mm.

The non-central rear surface geometry may conveniently be connected to the central optical geometry via a tangent and typically achieves the required overall sagittal depth by implementing a spline function (e.g. a Bezier spline function).

The central front optical surface of the contact lens is preferably an aspheric surface or toroidal aspheric surface having the definition as follows:

$$Z = (X^2 / R_X + Y^2 / R_Y) / (1 + \sqrt{1 - (P_X X^2) / R_X^2 - (P_Y Y^2) / R_Y^2})$$

5

where:

Z, R_X and R_Y and P_X and P_Y are all as defined above.

10 The non-central front surface geometry may conveniently be connected to the central optical geometry via a tangent and typically achieves the overall sagittal depth required to ensure that the contact lens edge thickness remains equal around the whole lens circumference.

15 Preferred range values for the difference in sagittal depth between the vertical meridian and the horizontal meridian (the vertical meridian preferably having the greater sagittal depth) include the following: 50-300µm; 50-200µm; 100-500µm; 100-300µm; 100-200µm and 120-200µm.

20 In contrast to the present invention, in conventional contact lenses, the rear surface is designed such that the sagittal depth of the vertical and horizontal meridians in the rear non-central portion is equal.

25 For the purposes of clarification, if required, the vertical meridian is the meridian of the contact lens which, when the lens is worn on eye in the intended angular orientation, is substantially vertical, and the horizontal meridian is substantially horizontal, such that the two meridians are orthogonal.

30 In a second aspect, the invention provides a method of designing at least the back surface of a contact lens adapted and configured for a subject from a particular ethnic group and/or geographical region, the method comprising the steps of:

(a) obtaining an averaged non-central anterior ocular surface profile for subjects from the ethnic group and/or geographical region of interest, and (b) applying this profile to the corresponding portion of the back surface of a contact lens design.

5 The step of obtaining an averaged non-central ocular surface profile for subjects from an ethnic group and/or geographical region of interest may simply comprise obtaining a profile which has been determined by another party, if such profile information is available. Alternatively, the step may comprise examining a plurality of subjects of the relevant ethnic group and/or from the relevant geographical region so as to obtain
10 NCAOS profile data, and deriving from those data an averaged profile.

The method preferably further comprises the step of making a lens according to the design produced in step (b).

15 Preferably the lens of the invention has a diameter which is great enough that the lens extends to cover the corneo-scleral junction. Conventionally, only soft contact lenses are made in this size. Typically therefore the invention applies to soft contact lenses, and to the design and manufacture of soft contact lenses. However, the invention may also be applied to the rigid contact lenses, if desired, where the lenses are large
20 enough to extend to the corneo-scleral junction. Conventional materials for manufacturing soft contact lenses comprise hydrogels, especially silicone hydrogels, but other materials are also suitable.

The invention is especially useful in relation to contact lenses which, on eye, have a
25 particular desired rotational orientation, and accordingly require a rotational stabilising means. Such lenses can include, for example, toric lenses or other lenses that require the application of optical prism, or for the correction of higher order optical aberrations. Alternatively, or additionally, the invention is especially useful in relation to contact lenses which require accurate centration, such as multifocal lenses.

30

In a preferred embodiment, the invention provides a contact lens wherein any necessary rotational stabilisation and/or centration is provided substantially entirely by means of the fit of the back of the lens to the surface of the subject's eye, and

especially the fit to the non-central anterior ocular surface. In particular, the invention allows for the design and manufacture of a contact lens, especially a soft contact lens (and more especially a toric soft contact lens), which is rotationally stabilised on eye, without any ballast or rotational stabilisation means incorporated on the front surface
5 of the lens, and provides a contact lens of that type.

In a third aspect, the invention provides a method of manufacturing a contact lens, the method comprising the steps of:

- 10 (i) making a lens in which at least part of the back surface of the lens in the non-central anterior ocular surface region is adapted and configured to fit an averaged non-central anterior ocular surface profile for subjects from a particular ethnic group and/or geographical region of interest;
- (ii) packaging the lens in sterile condition.

15 The contact lens made by the method of the third aspect of the invention may conveniently have been designed by a method in accordance with the second aspect of the invention, and performing the method of the third aspect will desirably result in the manufacture of a contact lens in accordance with the first aspect.

20 The invention thus provides in preferred embodiments, a contact lens in accordance with the first aspect, especially a soft contact lens, and more especially a toric soft contact lens, which has a back surface in the non-central ocular surface region which is adapted and configured to fit an averaged non-central anterior ocular surface profile for subjects from a particular ethnic group and/or geographical region.

25 In particular, the ethnic group is other than Caucasian and/or the geographical region is other than Europe or a part thereof (especially other than Western Europe). In one embodiment the contact lens has a back surface, over at least part of the non-central anterior ocular portion, which is adapted and configured to fit an averaged non-central
30 anterior ocular surface profile for an Asian subject, more especially a Taiwanese subject, although in principle the invention is equally applicable to the design of a contact lens for other ethnic groups and/or geographical regions. Particular geographical regions of interest may include China, Japan and the Caribbean.

In a preferred embodiment, the contact lens of the invention is one in which any necessary rotational stabilisation is provided substantially entirely by means of the fit of the back surface of the lens to the surface of the subject's eye, especially by the fit to the NCAOS. In particular, the invention allows the design and manufacture of a contact lens, especially a soft contact lens (and more especially a toric soft contact lens), which is rotationally stabilised on eye, without any ballast or rotational stabilisation means incorporated on the front surface of the lens.

By way of explanation, the present inventors have surprisingly found that the averaged curvature of the surface of human eyes in the NCAOS is markedly different between subjects from different ethnic groups and/or geographical regions. This surprising discovery led to the present invention. Specifically, it was found that, for an average Asian subject (especially an average Taiwanese subject), the vertical meridian was more steeply curved than the horizontal meridian in the NCAOS. It was also found that the NCAOS profile of an average Asian subject differed between right and left eyes. Obviously there are individual subjects among ethnic groups and/or from particular geographical regions whose eye profile deviates from the average, but when a sufficiently large number of typical representative subjects are examined, an average can be found which is quite different to an averaged profile from other ethnic groups or geographical regions. Preferably the averaged profile is based on measurements made using normal adult subjects ('normal' in this context meaning subjects without corneal defects, such as keratoconus, which are readily apparent upon examination by a reasonably competent practitioner).

In preferred embodiments, the method of the second or third aspects of the invention, and the contact lens of the first aspect of the invention, are such that the back surface of the lens (and more specifically that part of the back surface of the lens outside of the central zone) is not rotationally symmetrical.

In preferred embodiments, the method of the second or third aspects of the invention, and the contact lens of the first aspect of the invention, are such that, when compared to a conventional contact lens design (adapted and configured to fit an average

Caucasian subject), the back surface of the lens (and more specifically, that part of the back surface of the lens which, on eye, overlays the NCAOS) has a vertical axis (on eye) which is more steeply curved (i.e. has a smaller radius of curvature) and a horizontal axis (on eye) which is less steeply curved (i.e. has a larger radius of curvature).

In preferred embodiments the method of the first or second aspects of the invention, and the contact lens of the third aspect of the invention, are such that there is provided a pair of contact lenses for a patient, one for each of the patient's eyes, and wherein the back surface of each of the lenses is not rotationally symmetrical (more specifically that part of the back surface of the lens outside of the central zone). Additionally, in preferred embodiments, the non-rotationally symmetric profile on the non-central back surface of the lens for the patient's right eye will be different to that for the patient's left eye. The pair of contact lenses may be provided in sterile condition and as a plurality of such pairs, in conventional containers for contact lenses.

It will be apparent to the person skilled in the art that the preferred aspects (which, in this context, includes those described as "convenient", "desirable", "advantageous" and the like) of one aspect of the invention will generally be applicable also to the other aspects of the invention, unless the context dictates otherwise.

The invention will now be further described by way of detailed illustrative examples, and with reference to the accompanying drawings in which:

Figures 1(a) and 1(b) are representations of a normal human eye with (Fig. 1a), or without (Fig. 1b), a contact lens in place, and showing various features;

Figure 2 is a schematic representation showing the operation of the eye surface profiler;

Figure 3 shows two plots; the upper plot is a graph of tangent angle (in degrees) against displacement (in mm) from the centre of the cornea; and the lower plot shows

a graph of displacement (in mm) in the X, Y and Z axes of an orientation-adjusted eye profile;

Figures 4a and 4b are graphs comparing the vertical and horizontal meridians in averaged AOS profiles. More specifically, the figures compare differences in sagittal height (in μm) between the two meridians at various displacements (in mm) from the corneal apex. Figure 4a compares these meridians in averaged right eyes, and figure 4b in averaged left eyes. In both figures, linear symbols represent the averaged Caucasian eye profiles and circular symbols the averaged Taiwanese eye profiles;

Figures 5a and 5b are two different views of the same three dimensional graph showing the difference in elevation (in mm, vertical axis) between the average Caucasian eye profile and the average Taiwanese eye profile at various displacements (in mm, planar axes) from the corneal apex;

Figure 6 is a plan view of the front of an embodiment of a lens according to the invention, and Figures 6b and 6c are cross-sectional views through the lens at different meridians; and

Figures 7a and 7b are cross-sectional views of a contact lens in accordance with the invention along the vertical and horizontal meridians respectively.

Detailed Description of the Invention

Referring first to Figures 1(a) and 1(b), various features of the human eye, and of conventional contact lens fitting techniques, are described.

In Figure 1(a), dimension 'A' indicates the optic zone. This is a circle, typically of 8mm diameter, and is the portion of the eye over which the back surface of the lens is conventionally assigned a "base curve". Dimension 'B' marks the Horizontal Visible Iris Diameter or HVID. Typically the HVID is around 11.5mm. The precise location of the limbus or corneo-scleral junction cannot be readily determined by viewing the exterior of the eye. Accordingly the HVID, which can be determined, is taken as a rough approximation as the location of the limbus. Dimension 'C' denotes the

diameter of typical soft contact lens. The edge of a soft contact lens usually extends beyond the limbus. For most disposable contact lenses, the diameter C is in the range 13.8 – 14.6mm. Some soft lenses are larger than this, up to about 15.5mm.

5 In Figure 1(b), dimension D indicates the “central zone”. This is a circle of 6mm in diameter and encompasses that portion of the eye which is generally used by practitioners to determine the curvature of the cornea using a keratometer. ‘E’ denotes the outer limit of the limbus, and ‘F’ denotes the outer edge of the anterior ocular surface (AOS), which is defined by area of the sclera visible when the subject
10 gazes straight ahead and the eyelids are separated manually to their fullest extent. Accordingly, the non-central anterior ocular surface (NCAOS) of the eye is that part of the AOS which lies outside of the central zone and is bounded at its inner edge by D and at its outer edge by F.

15 **Discovery**

It was noted by the inventors that customised soft contact lenses that fit well for Caucasian eyes did not fit as expected on eyes in patients in Taiwan.

20 Also, if lenses demonstrating a sub-optimal fit were replaced with others in accordance with conventional fitting rules, the expected improvement in overall fit was not achieved. Indeed, in some cases, although some fit characteristics were improved, others were made worse.

25 Additionally, in other cases, identical lenses fitted to right and left eyes showing essentially the same K readings and HVID could behave quite differently. This suggested that K readings in particular were possibly a poor predictor of the shape of the eye beyond the central zone.

30 Examination of the eyes of the patients in Taiwan using the Eye Surface Profiler (see below) showed that differences in the non-central anterior ocular surface existed between right and left eyes and that these differences would in themselves account for the fit differences seen between right and left eyes.

Further Investigation

In order to examine possible fitting issues between Caucasian and Asian ethnic groups, an eye evaluation of contact lenses was performed for a cohort of 66 Taiwan subject eyes using a contact lens design known to work well in Caucasian eyes. Each eye was measured with the Eye Surface Profiler, and an equivalent number of Caucasian eyes were measured for comparison using the same equipment.

Contact lenses were evaluated and recordings made of the findings in terms of centration, movement, rotation, comfort and visual acuity. Additionally, each slit lamp subject examination was video recorded for later analysis.

Fit of the lenses was assessed in relation to conventional fitting rules established for normal eyes (e.g. as described in “The Contact Lens Manual: A Practical Fitting Guide” by Andrew Gasson & Judith Morris, 2nd edition, Butterworth Heinemann ISBN 0-7506-3187-2).

The fit of these lenses was then compared to the non-central anterior ocular surface of the Taiwanese and Caucasian eyes. Additionally, the averaged profile of the Caucasian anterior ocular surfaces was compared directly to those of the Taiwanese eyes.

Eye Surface Profiler (“ESP”)

(Eaglet Eye b.v. Lange Schaft 7 G-11, 3991 AP Houten, The Netherlands)

The availability of a new instrument, the Eye Surface Profiler (“ESP”), has allowed more detailed examination of the eye beyond the boundaries of the limbal area. ESP is a system for measuring the anterior surface of the eye using Fourier Transform Profilometry. Up to 20mm diameter of the Anterior Ocular Surface (AOS) can be measured. To acquire a measurement, fluorescein is instilled in the eye enabling light projected from two light sources to be scattered back from the eye front surface. (See projection 1 & 2 in Fig. 2). The ESP apparatus comprises a digital camera 2, and first and second projectors 4, 6. The scattered light forms vertical stripes which, when superimposed on each other, form interference patterns.

From these patterns, the ESP calculates a 3-dimensional model of the anterior surface of the eye with, on average, more than 250,000 measurement points from which the maps and parameters are calculated. A typical output is the 3D height map 8 shown in Figure 2.

The portion of the eye analysed by the ESP extends well beyond the 4mm diameter zone afforded by keratometers and allows examination of the limbus and sclera. Previously, access to this area could only be obtained by using cast moulding techniques, similar to those used to produce dental moulds, which is quite intrusive for the subject.

The analysis of the ESP data from Caucasian or Taiwanese subjects was used to compare the eyes of the two subject groups. However, in order to make a valid comparison, it was necessary to ensure that all data were from eyes in the same orientation. This was far from straightforward, given the lack of identifiable anatomical features on the eye. In particular, when subjects are analysed using an instrument such as the ESP, which is positioned close to the eye, there is a tendency for the eyes to converge, to look at the instrument (i.e. both eyes tend to rotate inwards towards the nose).

When working with the output of the ESP, it was discovered that the orientation of the anterior eye surface was assigned by the apparatus in an unscientific manner. This had the result that when attempting to identify and measure the orientation of anatomical entities such as the limbus, it was impossible objectively to justify that particular orientation. As this had a serious effect on calculations based on the machine output, it was decided to create new software, "SpiritLevel", which took the raw output from the ESP and applied a scientifically justifiable levelling technique.

Essentially, SpiritLevel works as follows. It is known that there is a significant change in the curvature of the anterior eye surface at the corneo-scleral junction. This fact was used to develop a technique whereby the angle of the tangent to the surface at each point on the eye is calculated. The software then detects the peaks of the angles

(Fig. 3, upper plot) which define the shape of the limbus. This shape is then projected onto the height map output calculated from the ESP data. Once this is done, the surface is rotated to make the limbus shape horizontal (Fig. 3 lower plot).

- 5 The technique works for substantially all corneal shapes and does not require a source image in order to detect the limbus, and it is possible to use the technique in conjunction with outputs from other types of instrument (such as a corneal topographer), not just an eye surface profiler.
- 10 In this way, it was possible for the inventors to make accurate and valid comparisons between profiles obtained from different subjects.

When comparing the profiles of the eyes from Caucasian subjects with those from Taiwanese subjects, the inventors surprisingly found that the average profile differed quite considerably, especially outside the central 6mm diameter zone i.e. in the NCAOS. They also found, even more surprisingly, that there were differences between the profiles of the right eye and the left eye in each ethnic group, and significantly more so in the Taiwanese subjects. Thus, not only should it be possible to design a contact lens with a back surface which has improved fit for a subject from a particular ethnic group and/or geographical region, but it should also be possible to design a lens which has a back surface adapted and configured to provide an improved fit for the subject's right or left eye, as appropriate.

Representative data from the inventors' findings are shown in Figures 4 and 5.

25 Figures 4a and 4b show how the mean Taiwanese AOS exhibits a greater difference between horizontal and vertical curvature than the mean Caucasian AOS. This difference in curvature is established by subtracting the vertical sagittal profile from the horizontal sagittal profile, where the convention for the profile orientations is that: the nasal and inferior directions are coincident for OD (i.e. right) eyes; and the temporal and inferior directions are coincident for OS (i.e. left) eyes. This choice of orientation is to preserve, as best as possible, the representation that the profiles are viewed as they would appear if viewing the subjects' actual eyes.

Figure 4a charts the profile differences in the mean right eye AOS's and figure 4b the corresponding differences in the mean left eye AOS's. In both figures the horizontal axes represent the distance, in millimetres, from the corneal apex; the choice of which direction(s) to take as positive differs between the figures, based upon the convention described above. The vertical axes represent the difference, measured in micrometres, in sagittal height between the horizontal and vertical meridians.

The figures show that in both right and left eyes, and in both Caucasian (linear symbols) and Taiwanese (circular symbols) groupings, the trend is for the AOS to be flatter horizontally than vertically. The trend is also for the flattening to increase with distance from the corneal apex; and although the figures suggest that the flattening decreases in the periphery of the AOS (particularly in the Caucasian mean AOS), this may be due to the interference of lids and tear pooling with the Eye Surface Profiler measurement near the edge of the AOS.

It can be seen that the magnitude of the horizontal flattening in many areas of any of the mean eyes is greater than the magnitude of the flattening that would be seen if one were to compare two spherical contact lenses whose base curves differ by one step; in some areas of the Taiwanese mean profiles, the magnitude of the flattening is greater than a two-step base curve change in a spherical lens. This suggests that the horizontal flattening trend is significant enough to cause fit issues that cannot be solved by a simple change of back surface curvature.

It is also apparent that in both eyes, and in both ethnicity groupings, the horizontal flattening does not develop in a symmetrical fashion on either side of the corneal apex. This asymmetry is visibly more pronounced in the Taiwanese mean AOS than the Caucasian mean AOS, and furthermore is more pronounced in the Taiwanese right mean eye than the left mean eye. These observations suggest fitting issues with the Taiwanese population that cannot be solved by fitting a contact lens with a currently existing toric back surface design, since such designs are all rotationally symmetric and do not take account of the observed asymmetry in the mean AOS's.

The differences between the mean profiles are also presented in Figures 5a and 5b. Figures 5a and 5b are two views of a three dimensional graph showing the difference in sagittal depth (in mm, vertical axis) between the average Caucasian eye AOS profile and the average Taiwanese eye AOS profile at various displacements (in mm, planar axes) from the corneal apex.

These mean AOS profiles combine the data from the right and left eyes; in order make this combination meaningful, the left eye data were reflected in the line running through the corneal apex from the superior to the inferior of the AOS.

If the two mean AOS profiles were identical then the graph in figures 5a and 5b would show a horizontal plane, since the difference in elevation would be zero in every position on the AOS. Since the graph is not a horizontal plane, the AOS's therefore exhibit some differences. In fact the graph is a "saddle" shape, where the largest positive values occur in the horizontal periphery, and the largest negative values occur in the vertical periphery. This indicates that the mean Taiwanese AOS is flatter in the horizontal periphery, and steeper in the vertical periphery, than the mean Caucasian AOS.

This saddle shape implies that contact lens fit issues in the Taiwanese population, which arise from a difference in AOS shape to the Caucasian population, are highly unlikely to be soluble by a simple adjustment to the back surface curvature of an existing contact lens design. To clarify, if one steepens the curvature to better match the shape of the vertical periphery, then the lens becomes too tight in the horizontal periphery; conversely if one flattens the curvature then a better fit horizontally is offset by a looser fit vertically.

A consequence of this is that standard contact lenses made according to conventional designs, based on experience with Caucasian subjects, do not fit very well in the NCAOS region when worn by Taiwanese subjects. Accordingly, the invention provides for contact lenses having different back surfaces in the NCAOS region with improved fit for Taiwanese subjects.

In addition, because the profile of Taiwanese subjects' eyes in the NCAOS region is more asymmetric than that in Caucasian eyes (upon which most current globally successfully contact lens designs are based), it is possible to confer sufficient rotational stabilisation on contact lenses for Taiwanese subjects by using an asymmetric design (especially in the NCAOS region) to assist in lens stabilisation on eye and, if desired, to dispense with 'ballast' features or other rotational stabilising means on the front surface which are conventional in contact lenses for Caucasian subjects when rotational stabilisation is required (e.g. for toric lenses).

In order to design a back surface of a contact lens to fit a non-Caucasian ethnic group, it is possible to adopt a number of different approaches. In one approach, with knowledge of the comparison of the average profiles of a Caucasian subject and a subject from the ethnic group of interest, one can determine the difference between the sagittal heights at a plurality of points – conveniently points lying on one or more axes, such as vertical and horizontal axes, and then adjusting an existing conventional "Caucasian" back surface design by applying the height differences at the selected plurality of points. Desirably the selected plurality of points on the back surface of the adjusted design are then joined by fitting a smooth surface via interpolation to complete the design of the back surface.

A detailed example of the above approach is now described with reference to Figures 6a-6c.

Figure 6a is a plan view of the front of a lens designed according to the method of the invention, and Figures 6b and 6c are cross-sectional views through the lens at different meridians.

In Figure 6a, "A" denotes the edge of the front optic zone (8.00mm in diameter), and "C" denotes the edge of the contact lens (the lens having a total diameter of 14.5mm). The peripheral front surface of the lens comprises three radial zones; PF1, PF2 and PF3.

In Figures 6b and 6c, the broken line indicates the edge of the base curve applied to the rear surface of the lens. M1 and M2 indicate different selected meridians on the back surface, and 'f' and 'g' denote arcs or spline curves, as desired, applied to the peripheral back surface of the lens at the respective meridians, selected to match the
5 desired sagittal heights.

Figures 7a and 7b are cross-sections through the lens in the vertical and horizontal meridians respectively. S_V indicates the sagittal depth of the vertical meridian of the contact lens and S_H indicates the sagittal depth of the horizontal meridian of the
10 contact lens.

The design method is as follows.

Firstly the central back surface curve is defined based on the standard fitting criteria
15 that are favoured by the person skilled in the art of contact lens manufacturing. In this example, an 8.60mm radius of curvature is used to define a spherical base curve out to a diameter of 12.00mm (dotted line in Figures 6b and 6c). The total diameter of the lens is defined again using the standard fitting criteria, in this example a total diameter of 14.50mm is selected. Secondly, a peripheral arc is added at numerous selected
20 meridians (examples shown as M1 and M2) extending from the centre of the lens outwards, on one side, to the edge of the lens. The radius of curvature of this peripheral curve (f and g respectively) is calculated to most accurately fit to a plurality of sagittal heights along this meridian from the diameter of the base curve out to the total diameter of the contact lens. This is repeated for all the selected meridians, for
25 example about 200 meridians (which number gives a satisfactory resolution for the fitting of the lens to the subject), around the complete lens. An alternative approach is to use a respective plurality of spline curves around the lens that pass through the plurality of sagittal heights rather than one single spherical arc per meridian.

30 Thirdly the front surface is calculated by determining the front optic radius of the lens from the required power. This may be a toric surface should the person skilled in the art desire a lens that exhibits a toric prescription. In this example the diameter of the front optic zone is 8.00mm.

Lastly the front peripheral area which may conventionally consist of 1, 2 or more radial zones (PF1, PF2, PF3 in Figure 6a), is designed to ensure that the edge thickness is consistent around the complete lens, at each meridian. The radius of each
5 of these zones is calculated based on the sagittal height of the back surface with the addition of the required lens thickness.

Claims

1. A contact lens, the back surface of which has a shape such that the sagittal depth of a vertical meridian in the non-central rear surface differs from the sagittal
5 depth of a horizontal meridian in the non-central rear surface by an amount in the range 50 μ m to 500 μ m.
2. A contact lens according to claim 1, wherein the sagittal depth of the vertical meridian on the non-central surface differs from, and preferably is greater than, the
10 sagittal depth of the horizontal meridian in the non-central surface by an amount in the range 100 μ m to 500 μ m.
3. A contact lens according to claim 1, wherein the sagittal depth of the vertical meridian on the non-central surface differs from, and preferably is greater than, the
15 sagittal depth of the horizontal meridian in the non-central surface by an amount in the range 120 μ m to 500 μ m.
4. A contact lens according to claim 1, wherein the sagittal depth of the vertical meridian on the non-central surface differs from, and preferably is greater than, the
20 sagittal depth of the horizontal meridian in the non-central surface by an amount in the range 100 μ m to 300 μ m.
5. A contact lens according to claim 1, wherein the sagittal depth of the vertical meridian on the non-central surface differs from, and preferably is greater than, the
25 sagittal depth of the horizontal meridian in the non-central surface by an amount in the range 100 μ m to 200 μ m.
6. A contact lens according to claim 1, wherein the sagittal depth of the vertical meridian on the non-central surface differs from, and preferably is greater than, the
30 sagittal depth of the horizontal meridian in the non-central surface by an amount in the range 120 μ m to 200 μ m.

7. A contact lens according to any one of the preceding claims, which is a soft contact lens.
8. A contact lens in accordance with any one of the preceding claims, wherein
5 the contact lens has a toric front surface.
9. A contact lens according to any one of the preceding claims, wherein the contact lens has a desired orientation on eye and wherein any necessary rotational stabilisation of the contact lens is provided substantially entirely by means of the fit of
10 the back of the lens to the surface of the subject's eye on the non-central anterior ocular surface.
10. A contact lens according to claim 9, wherein the contact lens has no ballast or rotational stabilising means incorporated on the front surface of the lens.
- 15 11. A contact lens according to any one of the preceding claims, comprising a back surface in the non-central surface region which is adapted and configured to fit an averaged non-central anterior ocular surface profile for subjects from a particular ethnic group and/or geographical region, wherein the ethnic group is other than
20 Caucasian and the geographical region is other than Europe or a part thereof.
12. A contact lens according to claim 11, wherein the ethnic group is Asian.
13. A contact lens according to claim 11 or 12, wherein the geographical region is
25 Taiwan.
14. A method of making a contact lens, the contact lens being in accordance with any one of the preceding claims, the method comprising the steps of designing a contact lens, the back surface of which has a shape such that the sagittal depth of the
30 vertical meridian in the non-central surface differs from, and preferably is greater than, the sagittal depth of the horizontal meridian in the non-central surface by an amount in the range 50-500 μ m.

15. A method of manufacturing a contact lens, the method comprising the steps of:
- (i) making a lens in which at least part of the back surface of the lens in the non-central surface region is adapted and configured to fit an averaged non-central anterior ocular surface profile for subjects from a particular ethnic group and/or geographical region of interest;
 - (ii) packaging the lens in sterile condition.
- 5
16. A method of designing at least the back surface of a contact lens adapted and configured for a subject from a particular ethnic group and/or geographical region, the method comprising the steps of:
- (a) obtaining an averaged non-central anterior ocular surface profile for subjects from the ethnic group and/or geographical region of interest, and (b) using this profile to design the corresponding portion of the back surface of a contact lens design.
- 10
17. A method according to claim 15, which is further in accordance with claim 14.
- 15
- 20

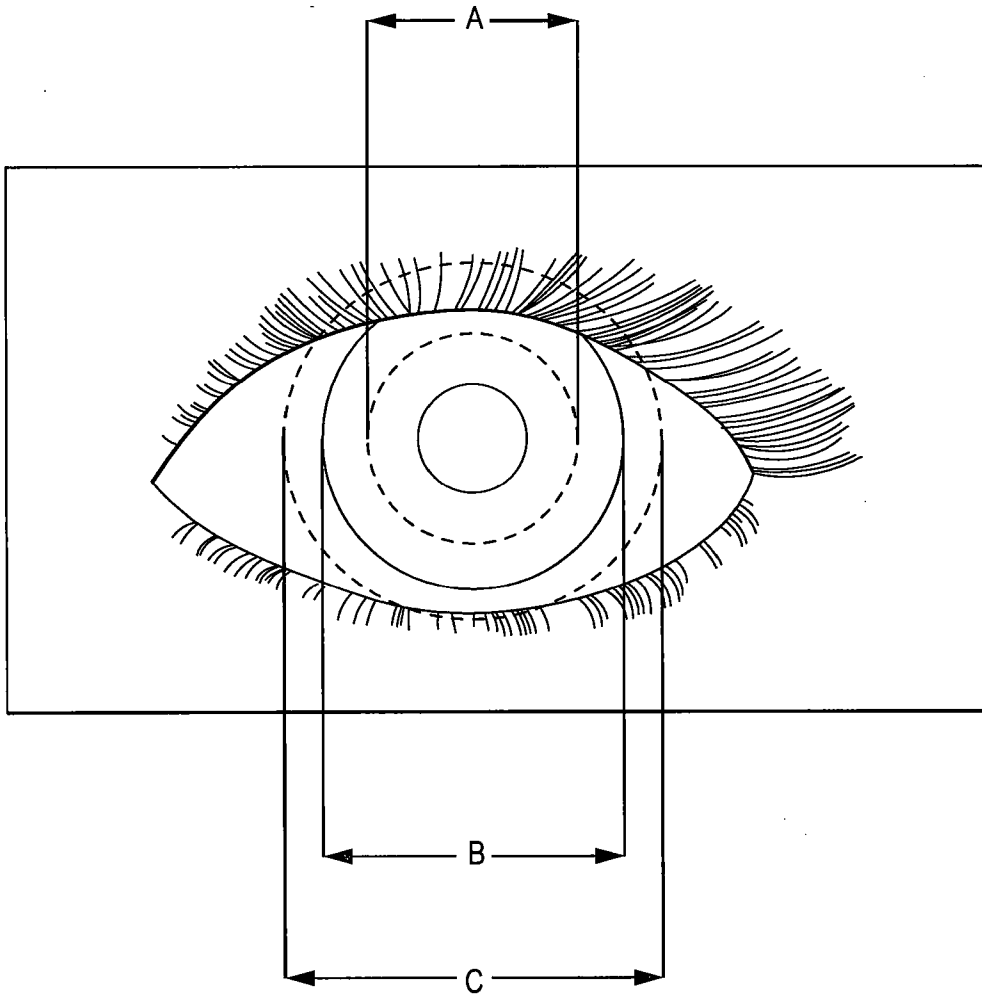

FIG. 1a

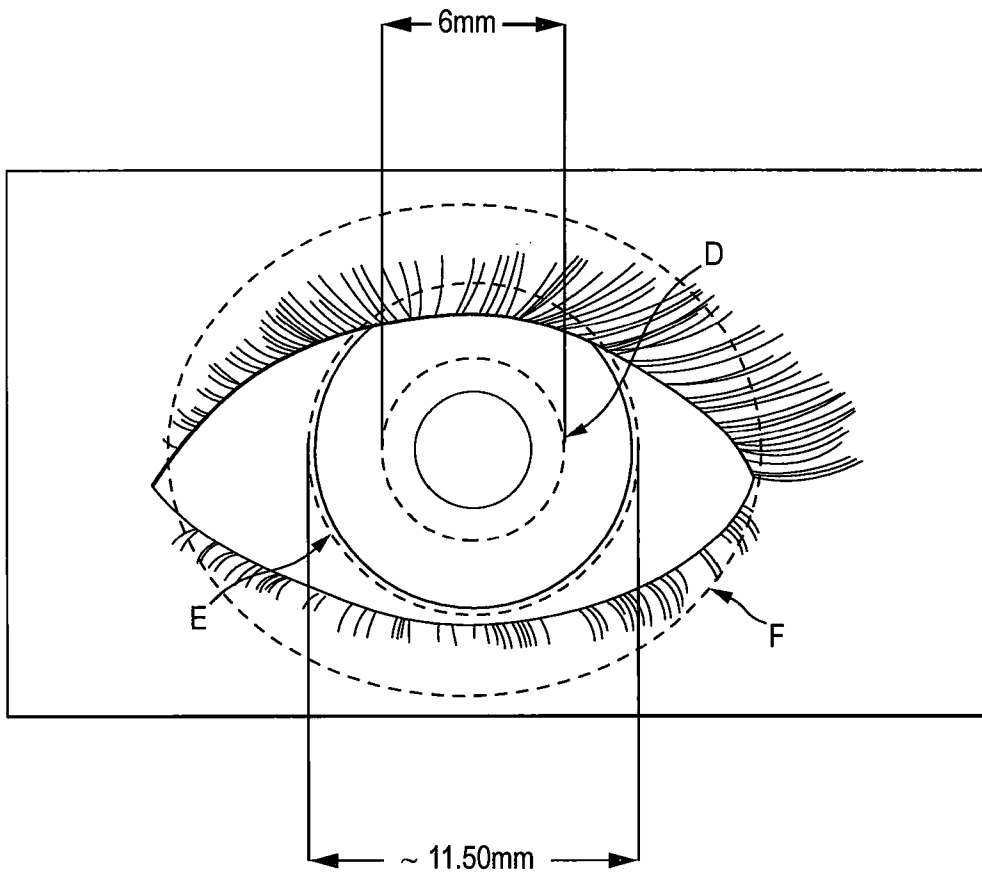

FIG. 1b

3 / 11

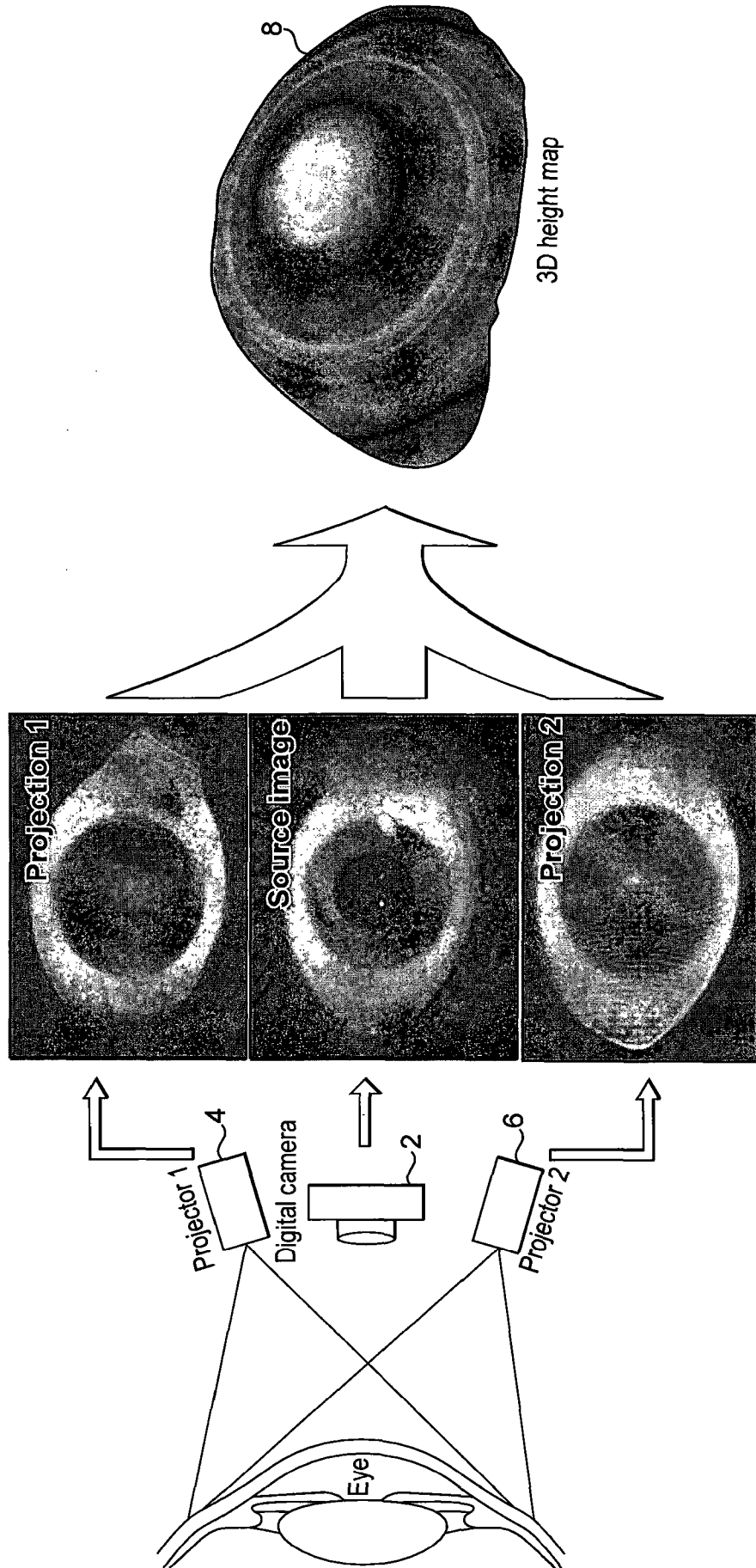

FIG. 2

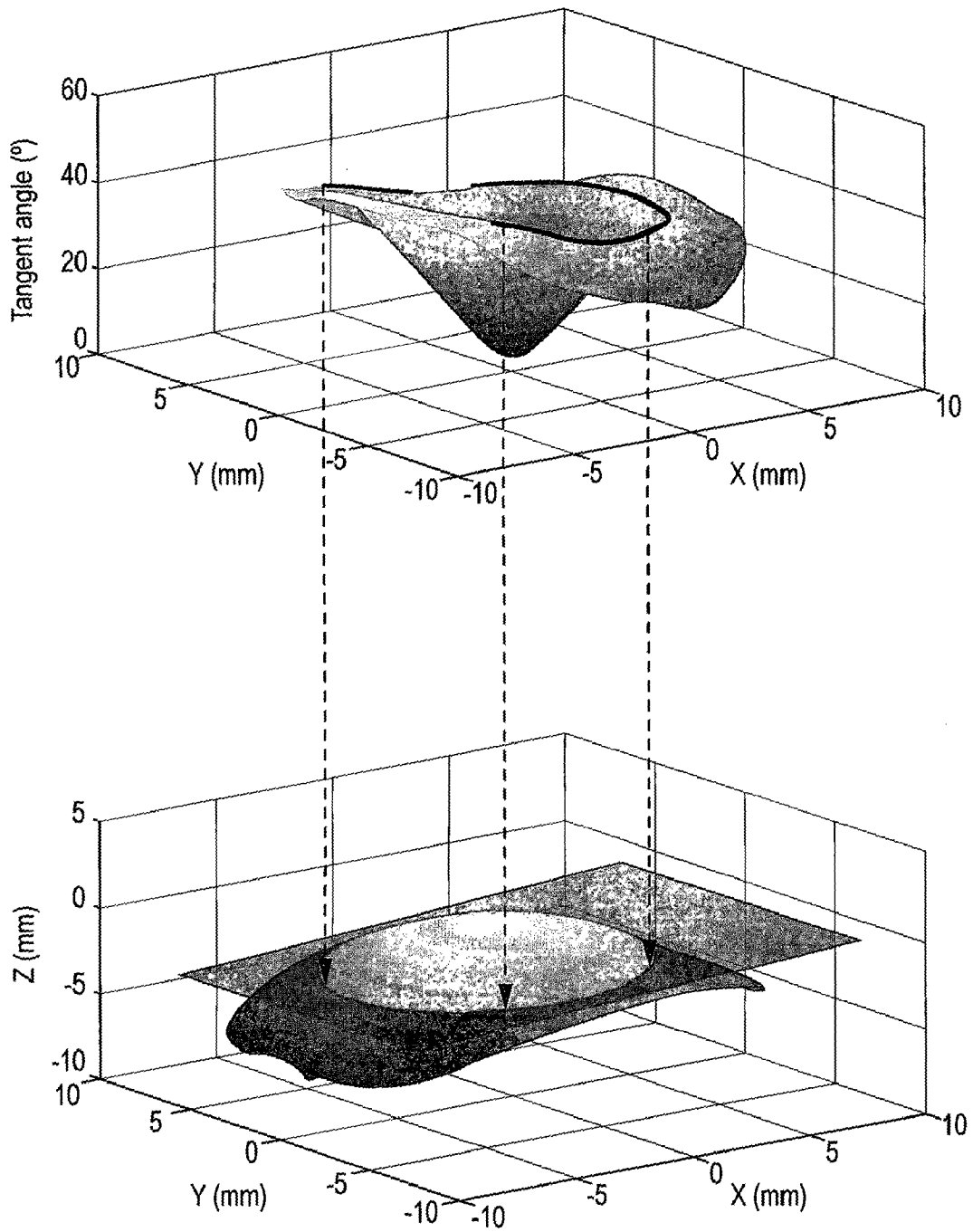

FIG. 3

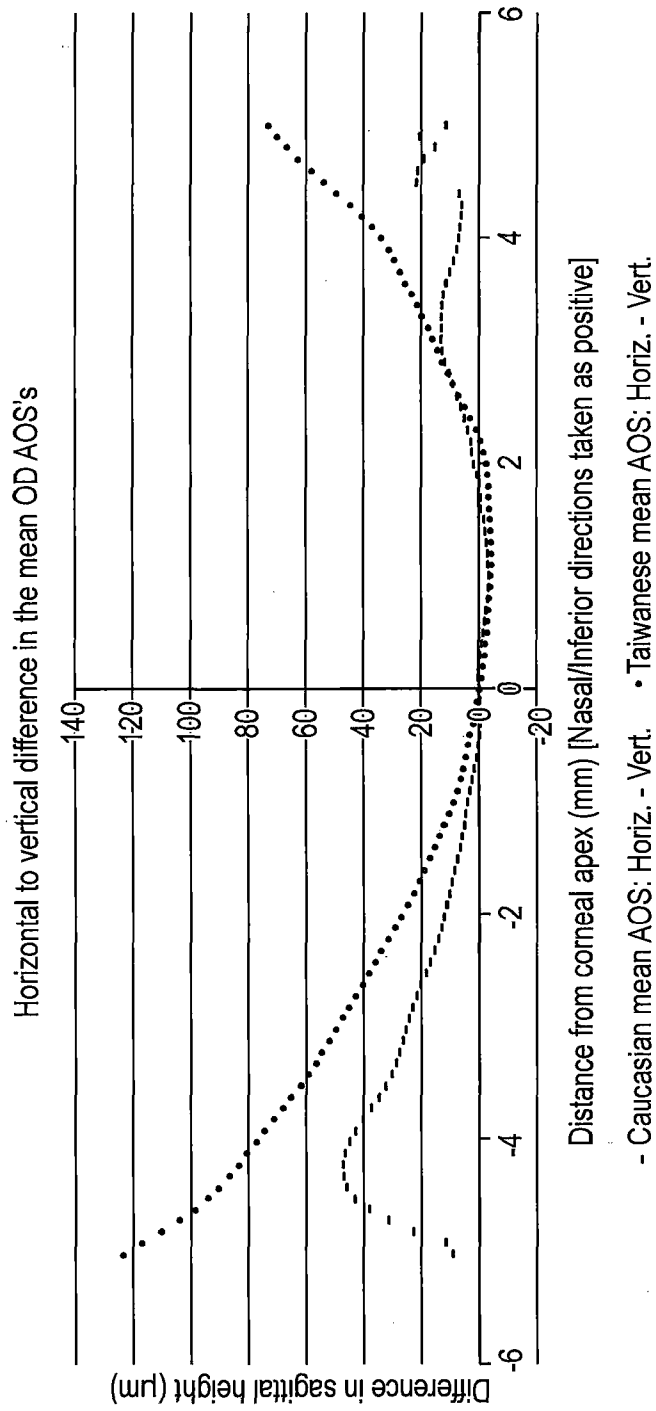

FIG. 4a

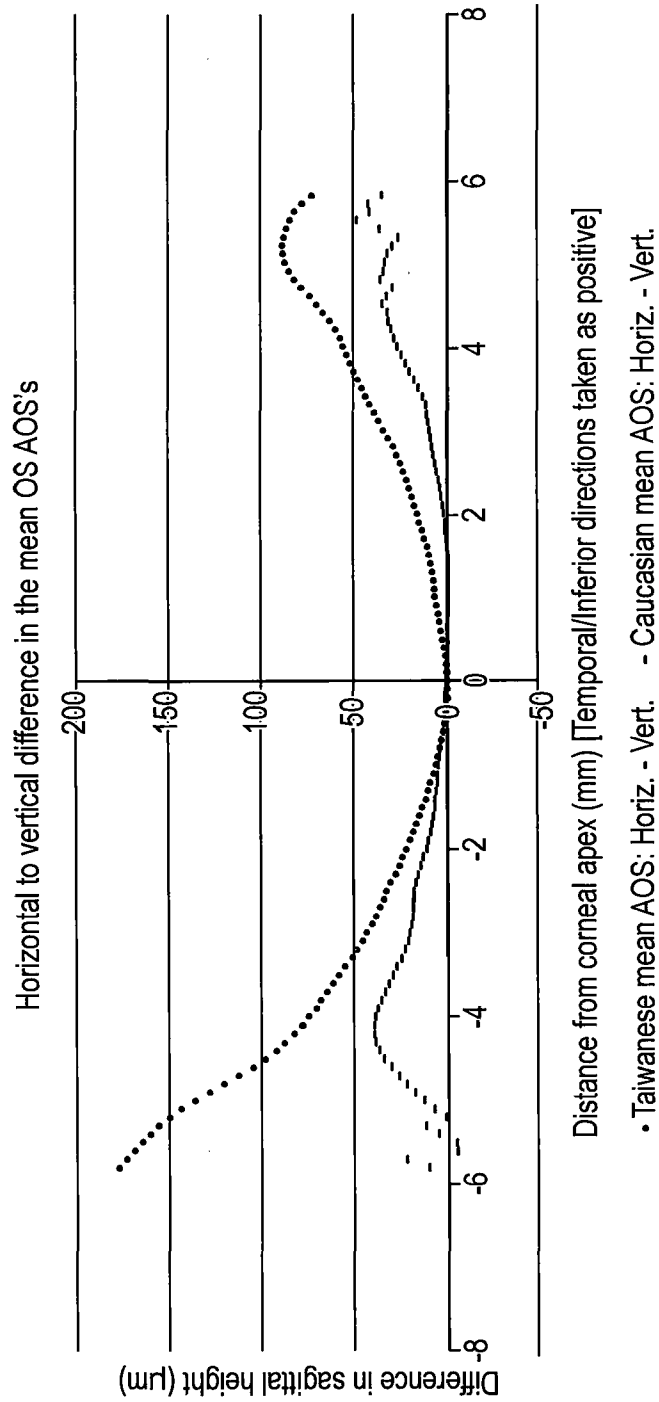

FIG. 4b

Difference in elevation between the mean Taiwanese and the mean Caucasian AOS

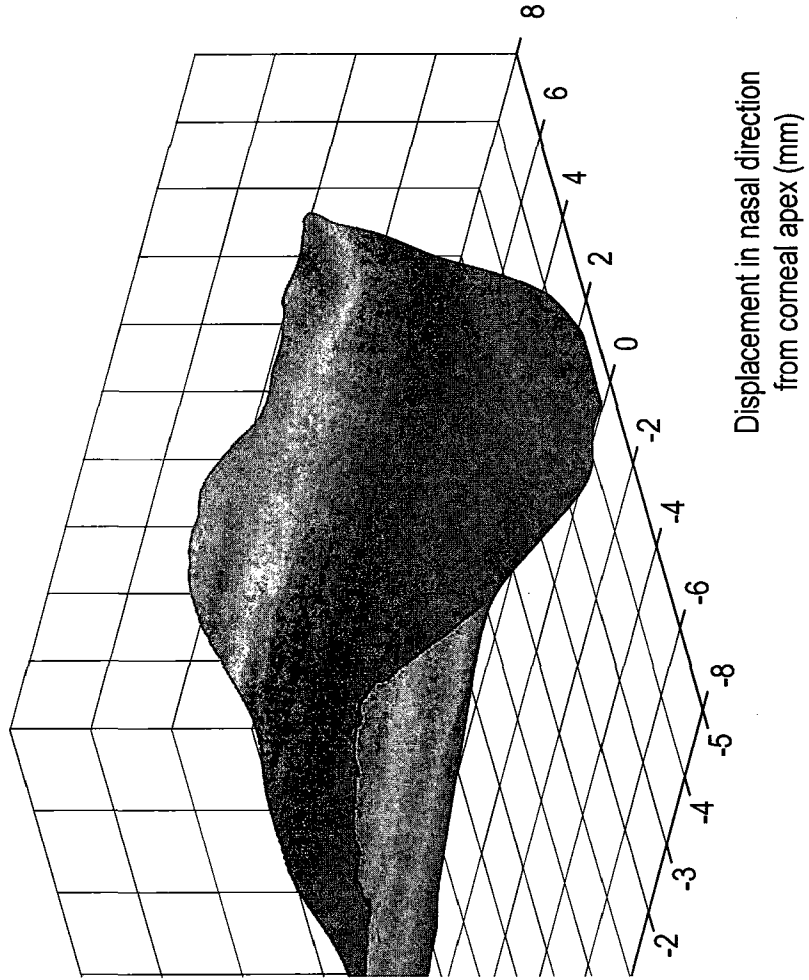

FIG. 5a

Differences in elevation between the mean Taiwanese eye and the mean Caucasian eye

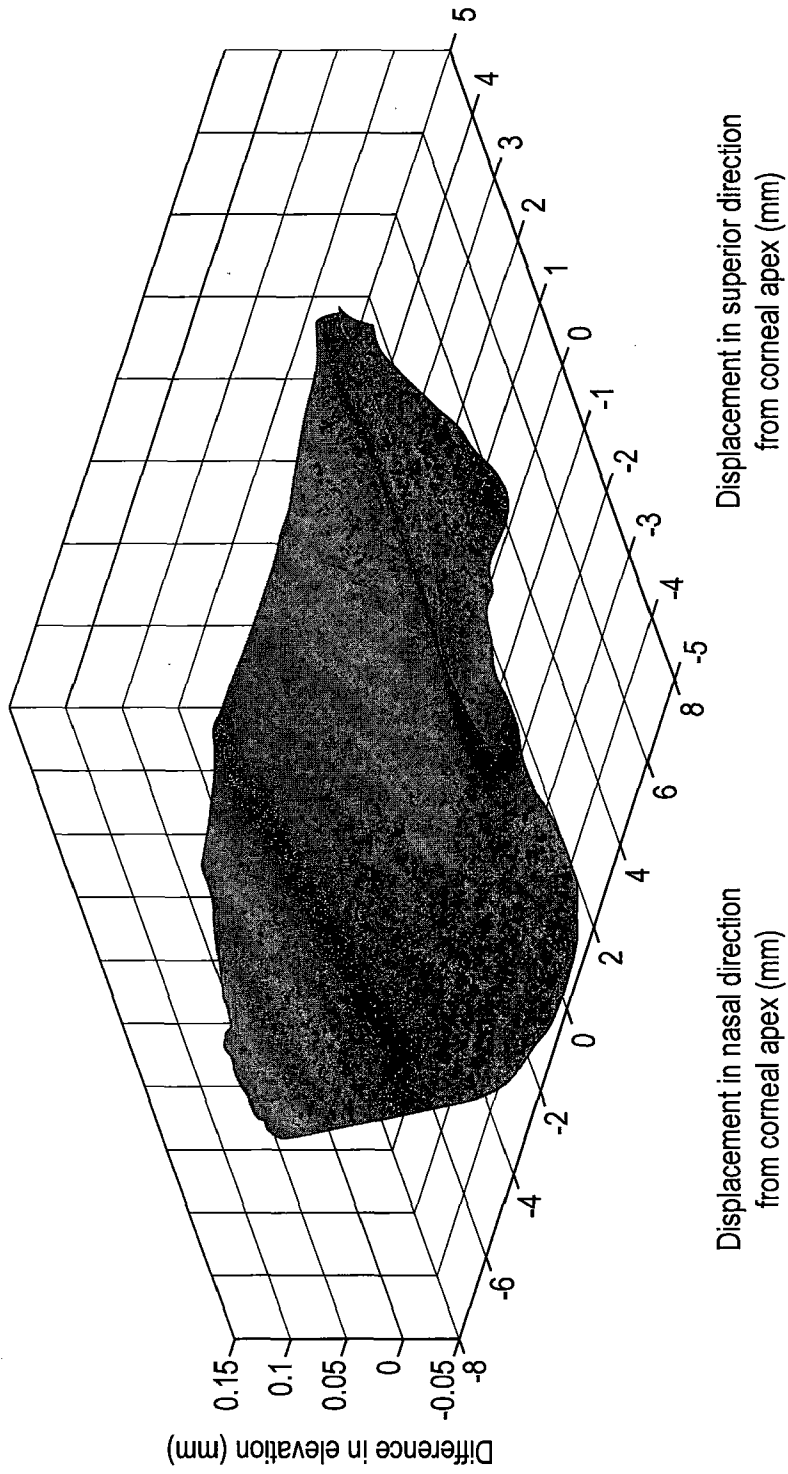

FIG. 5b

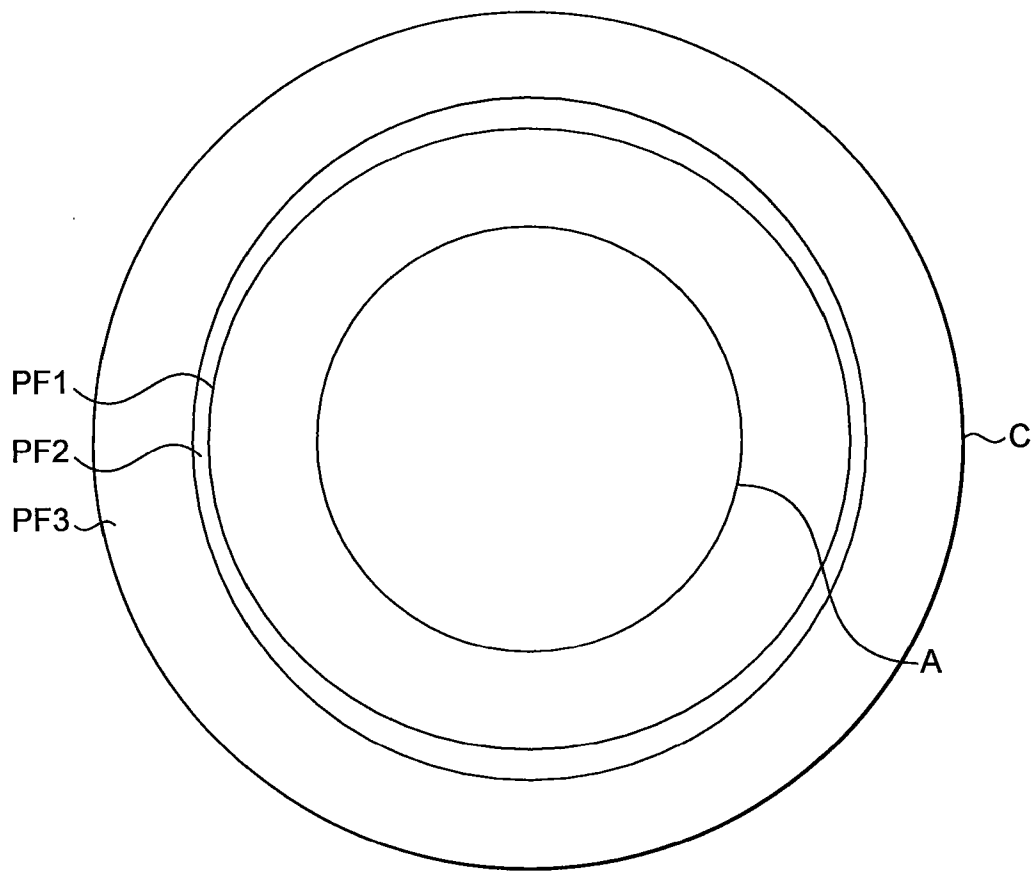

FIG. 6a

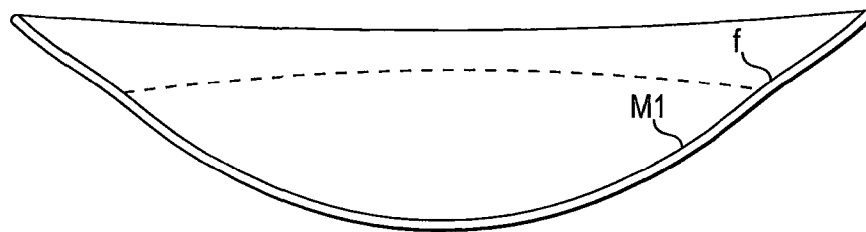

FIG. 6b

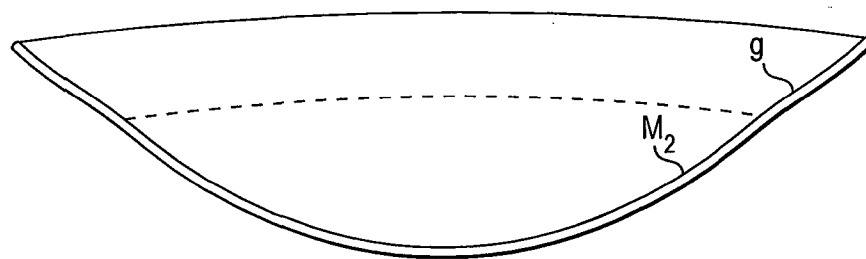

FIG. 6c

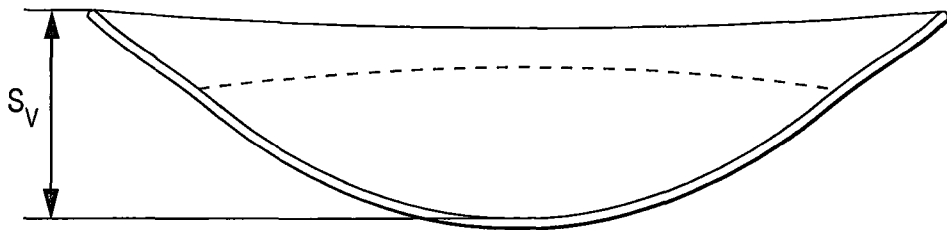

FIG. 7a

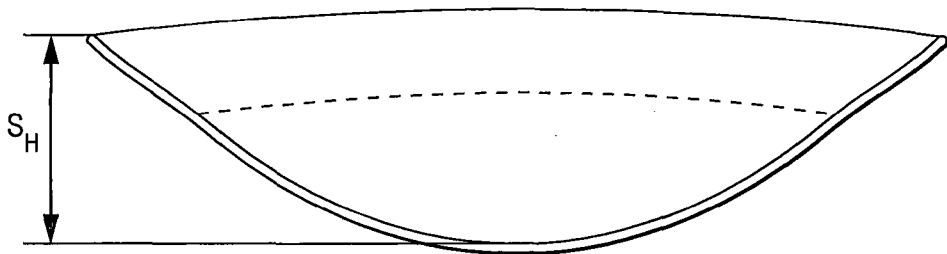

FIG. 7b

INTERNATIONAL SEARCH REPORT

International application No
PCT/GB2017/050793

A. CLASSIFICATION OF SUBJECT MATTER
INV. B29D11/00 G02C7/04
ADD.
According to International Patent Classification (IPC) or to both national classification and IPC

B. FIELDS SEARCHED
Minimum documentation searched (classification system followed by classification symbols)
B29D G02C
Documentation searched other than minimum documentation to the extent that such documents are included in the fields searched

Electronic data base consulted during the international search (name of data base and, where practicable, search terms used)
EPO-Internal, WPI Data

C. DOCUMENTS CONSIDERED TO BE RELEVANT		
Category*	Citation of document, with indication, where appropriate, of the relevant passages	Relevant to claim No.
X	US 2012/062835 A1 (CLAMP JOHN [GB] ET AL) 15 March 2012 (2012-03-15) abstract figures 5,7 paragraphs [0026], [0045], [0046], [0080], [0081], [0082] -----	1-14
X	US 2010/271589 A1 (LEGERTON JEROME A [US] ET AL) 28 October 2010 (2010-10-28) abstract figures 5d,5E paragraphs [0019], [0026], [0028], [0032], [0033], [0037], [0039], [0051] - [0057] ----- -/--	1-14

Further documents are listed in the continuation of Box C.

See patent family annex.

* Special categories of cited documents :

- "A" document defining the general state of the art which is not considered to be of particular relevance
- "E" earlier application or patent but published on or after the international filing date
- "L" document which may throw doubts on priority claim(s) or which is cited to establish the publication date of another citation or other special reason (as specified)
- "O" document referring to an oral disclosure, use, exhibition or other means
- "P" document published prior to the international filing date but later than the priority date claimed

"T" later document published after the international filing date or priority date and not in conflict with the application but cited to understand the principle or theory underlying the invention

"X" document of particular relevance; the claimed invention cannot be considered novel or cannot be considered to involve an inventive step when the document is taken alone

"Y" document of particular relevance; the claimed invention cannot be considered to involve an inventive step when the document is combined with one or more other such documents, such combination being obvious to a person skilled in the art

"&" document member of the same patent family

Date of the actual completion of the international search 18 May 2017	Date of mailing of the international search report 25/07/2017
Name and mailing address of the ISA/ European Patent Office, P.B. 5818 Patentlaan 2 NL - 2280 HV Rijswijk Tel. (+31-70) 340-2040, Fax: (+31-70) 340-3016	Authorized officer Heckmann, Paul

INTERNATIONAL SEARCH REPORT

International application No
PCT/GB2017/050793

C(Continuation). DOCUMENTS CONSIDERED TO BE RELEVANT		
Category*	Citation of document, with indication, where appropriate, of the relevant passages	Relevant to claim No.
X	US 2010/245759 A1 (LEGERTON JEROME A [US] ET AL) 30 September 2010 (2010-09-30) abstract figures 1-5 paragraphs [0020] - [0025], [0039] - [0041], [0051] - [0057], [0071] - [0077] -----	1-14
X	US 2013/297015 A1 (JOHNS LYNETTE K [US] ET AL) 7 November 2013 (2013-11-07) abstract figures 5A,5B, paragraphs [0052] - [0055], [0076] - [0079], [0083] -----	1-14
X	US 6 305 802 B1 (ROFFMAN JEFFREY H [US] ET AL) 23 October 2001 (2001-10-23) abstract columns 2-3 -----	1-14

INTERNATIONAL SEARCH REPORT

International application No.
PCT/GB2017/050793

Box No. II Observations where certain claims were found unsearchable (Continuation of item 2 of first sheet)

This international search report has not been established in respect of certain claims under Article 17(2)(a) for the following reasons:

1. Claims Nos.:
because they relate to subject matter not required to be searched by this Authority, namely:

2. Claims Nos.:
because they relate to parts of the international application that do not comply with the prescribed requirements to such an extent that no meaningful international search can be carried out, specifically:

3. Claims Nos.:
because they are dependent claims and are not drafted in accordance with the second and third sentences of Rule 6.4(a).

Box No. III Observations where unity of invention is lacking (Continuation of item 3 of first sheet)

This International Searching Authority found multiple inventions in this international application, as follows:

see additional sheet

1. As all required additional search fees were timely paid by the applicant, this international search report covers all searchable claims.

2. As all searchable claims could be searched without effort justifying an additional fees, this Authority did not invite payment of additional fees.

3. As only some of the required additional search fees were timely paid by the applicant, this international search report covers only those claims for which fees were paid, specifically claims Nos.:

4. No required additional search fees were timely paid by the applicant. Consequently, this international search report is restricted to the invention first mentioned in the claims; it is covered by claims Nos.:

1-14

Remark on Protest

- The additional search fees were accompanied by the applicant's protest and, where applicable, the payment of a protest fee.
- The additional search fees were accompanied by the applicant's protest but the applicable protest fee was not paid within the time limit specified in the invitation.
- No protest accompanied the payment of additional search fees.

FURTHER INFORMATION CONTINUED FROM PCT/ISA/ 210

This International Searching Authority found multiple (groups of) inventions in this international application, as follows:

1. claims: 1-14

Contact lens with sagittal depth of a vertical meridian in the non central rear surface that differs from the sagittal depth of a horizontal meridian in the non-central surface by an amount in the range of 50 to 500 micro-meter

2. claims: 15-17

Method for designing a contact lens with a non-central back surface adapted and configured to fit an averaged non-central anterior ocular surface profil

INTERNATIONAL SEARCH REPORT

Information on patent family members

International application No PCT/GB2017/050793

Patent document cited in search report	Publication date	Patent family member(s)	Publication date
US 2012062835	A1	15-03-2012	NONE

US 2010271589	A1	28-10-2010	CN 102428403 A 25-04-2012
			EP 2422236 A1 29-02-2012
			US 2010271589 A1 28-10-2010
			WO 2010123824 A1 28-10-2010

US 2010245759	A1	30-09-2010	CN 102449535 A 09-05-2012
			EP 2411861 A1 01-02-2012
			US 2010245759 A1 30-09-2010
			WO 2010111520 A1 30-09-2010

US 2013297015	A1	07-11-2013	US 2013297015 A1 07-11-2013
			US 2017102557 A1 13-04-2017
			WO 2013169812 A1 14-11-2013

US 6305802	B1	23-10-2001	AR 027493 A1 02-04-2003
			AU 769101 B2 15-01-2004
			BR 0013211 A 23-04-2002
			CA 2381624 A1 15-02-2001
			CN 1369065 A 11-09-2002
			CN 102778761 A 14-11-2012
			EP 1206722 A1 22-05-2002
			JP 4722356 B2 13-07-2011
			JP 2003506175 A 18-02-2003
			TW 553733 B 21-09-2003
			US 6305802 B1 23-10-2001
			WO 0111418 A1 15-02-2001
