

The Design of Relativistic Ultrafast Electron Diffraction and Imaging (RUEDI) Facility for materials in extremes

Yoshie Murooka¹, William Bryan², James Clarke^{3,4}, Michael Ellis^{3,4}, Angus I. Kirkland⁵, Simon Maskell¹, Julian McKenzie^{3,4}, B. Layla Mehdi¹, R. J. Dwayne Miller⁶, Timothy C. Q. Noakes^{3,4}, Ian Robinson⁷, Sven L. M. Schroeder^{8,9,10}, Jasper van Thor¹¹, Carsten Welsch^{1,4}, Nigel D. Browning¹

¹Physical Sciences & Engineering, University of Liverpool, Liverpool, L69 3GQ, UK

²Department of Physics, University of Swansea, Singleton Park, Swansea SA2 8PP, UK

³ASTeC, STFC Daresbury Laboratory, Warrington, WA4 4AD

⁴Cockcroft Institute, Sci-Tech Daresbury, Warrington, WA4 4AD

⁵Rosalind Franklin Institute, Harwell Science & Innovation Campus, Didcot, OX11 0QS, U. K

⁶Departments of Chemistry & Physics, University of Toronto, Toronto, Ontario M5G 1L5, Canada

⁷London Centre for Nanotechnology, University College, London WC1E 6BT

⁸School of Chemical and Process Engineering, University of Leeds, Leeds LS2 9JT, UK

⁹Diamond Light Source Ltd, Harwell Science & Innovation Campus, Didcot, OX11 0DE, U.K.

¹⁰EPSRC Future Continuous Manufacturing and Advanced Crystallisation Hub, Research Complex at Harwell (RCaH), Rutherford Appleton Laboratory, Harwell, Didcot, OX11 0FA, UK

¹¹Department of Life Sciences, Imperial College London, London, SW7 2AZ, UK

Materials in extreme conditions in terms of temperature and pressure are of great interest where noble phenomena are expected for new science and materials design. A wide range of materials are of interest, including warm dense matter, particulate materials, liquid materials, fusion materials and geophysical materials. Their environments also range from liquid phase, gas phase and cryogenic temperatures. The conditions often correspond to the level of the interiors of planets or stars. Such conditions are, however, typically not available in the laboratory. In addition, noble phenomena exist as transition structures that occur at an extremely short time scale in the tough environments that are often difficult to be modelled.

REUEDI [1,2,3] is designed to capture these ultrafast and noble phenomena in materials in terms of crystal structures and microstructures using electron diffraction and imaging. Figure 1 shows the working design of RUEDI. The RF electron source provides bright femtosecond pulses. The electron beam line is divided into diffraction and imaging due to the different requirements in electron optics and the specimen environment. The possibility of multiple electron sources is also investigated. The imaging line is unique compared to other MeV electron diffraction systems around the world. It uses 2MeV electrons and is expected to have a spatial resolution of a few nm and a temporal resolution of 1 ps. As with the diffraction line, both pump-probe and single-shot methods are available. Laser irradiation is available in a wide range of wavelengths, as well as TW high intensity irradiation. The specimen chamber can have rich specimen environments, including state-of-art gases/liquids/cryo stages. MeV electrons can be used to observe specimens thicker than 10s microns, which reveals fast defect dynamics in the bulk. In addition to the dynamics of nanostructures and lattice defects, the electromagnetic field can be also visualised due to the interaction between electrons and the field. Irradiation effects and experimental efficiency are optimised by introducing IT technologies. The diffraction line can achieve a pulse duration of 20fs due to the pulse compression that allows to cover most of phonon frequencies in materials.

Warm dense matter is vital in many of research areas, ranging from laboratory fusion to the interiors of giant planets, galaxies and in laser processing of solids. Intense pulsed lasers are used to create the conditions for WDM. Short-range correlations of atoms can be clarified by diffraction, while long-range complex motions can be visualised by imaging. The insight provided by RUEDI connects the microscopic and macroscopic aspects of WDM, where fundamental parameters such as viscosity and melting temperature are often not well characterised. Fusion materials need to be stable under extreme conditions. RUEDI provides insight into their bulk properties, as MeV electrons have a long penetration depth. When high power laser can achieve locally very high temperatures, ultrafast electron diffraction and imaging reveal the dynamics of defect formation, recovery processes and their migration in the material at such high temperatures. In geophysical materials, the irradiation with one or two intense pulsed lasers can introduce local strain that relates to microscopic insights of an earthquake. Electron diffraction and imaging are to gain microscopic knowledge of crystal structure and mass transport. This presentation will cover the RUEDI design, the use of technologies, electron diffraction, imaging and analysis at the RUEDI facility, with a particular emphasis on the observation of specimens under extreme conditions.

References:

- [1] RUEDI is supported by EPSRC / UK Infrastructure Fund under grant number EP/W033852/1.
- [2] <http://ruedi.uk>
- [3] Nigel D. Browning, William Bryan, James Clarke, Michael Ellis, Angus I. Kirkland, Simon Maskell, Julian McKenzie, B. Layla Mehdi, R. J. Dwayne Miller, Yoshie Murooka, Timothy C. Q. Noakes, Ian Robinson, Sven L. M. Schroeder, Jasper van Thor, Carsten Welsch, *Microsc. Microanal.* **28** (Suppl 1), (2022), p.2764

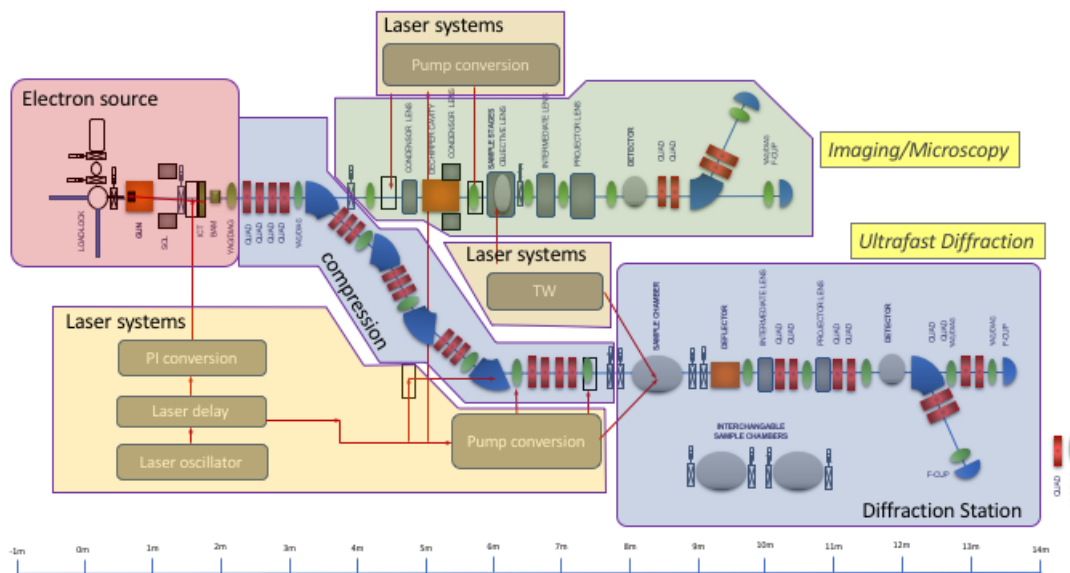

Figure 1: Working concept for the configuration of RUEDI system with diffraction and Imaging line.