

Smart Contracts for Decentralised Building Information Modelling

Theodoros Dounas¹, Wassim Jabi², Davide Lombardi³

¹Robert Gordon University ²Cardiff University ³Xian Jiaotong Liverpool University

¹t.dounas@rgu.ac.uk ²jabiw@cardiff.ac.uk ³davide.lombardi@xjtlu.edu.cn

The paper presents a model for decentralizing building information modelling, through implementing its infrastructure using the decentralized web. We discuss the shortcomings of BIM in terms of its infrastructure, with a focus on tracing identities of design authorship in this collective design tool. In parallel we examine the issues with BIM in the cloud and propose a decentralized infrastructure based on the Ethereum blockchain and the Interplanetary filesystem (IPFS). A series of computing nodes, that act as nodes on the Ethereum Blockchain, host disk storage with which they participate in a larger storage pool on the Interplanetary Filesystem. This storage is made available through an API is used by architects and designers creating and editing a building information model that resides on the IPFS decentralised storage. Through this infrastructure central servers are eliminated, and BIM libraries and models can be shared with others in an immutable and transparent manner. As such Architecture practices are able to exploit their intellectual property in novel ways, by making it public on the internet. The infrastructure also allows the decentralised creation of a resilient global pool of data that allows the participation of computation agents in the creation and simulation of BIM models.

Keywords: Blockchain, decentralisation, immutability, resilience, Building Information Modelling

INTRODUCTION

Scope

The paper describes a conceptual mechanism through which Building Information Modelling (BIM) applications can be developed in a decentralised environment, both in terms of the stakeholders participation and the infrastructure the software executes

on. Further we implement a decentralised BIM prototype, running as smart contracts on the Ethereum Blockchain and IPFS, as validation to the concepts described. Our premise for developing the concepts and prototypes within, lie within the potential of the blockchain mechanism for identity and authorship management, immutability and resilience of data, and decoupling of the data from “cloud” infrastruc-

tures that might be used for work and dissemination. While computing “clouds” have appeared as a solution to collaboration between different design agents, the provision of centralised servers and clouds controlled by the companies that provide it, undermine data integrity and ownership

Context

BIM has been praised as an end-all solution for various architectural design processes however the idealistic view of an all-encompassing tool differs to views of BIM from practice. [Holzer], echoing [Maver] and the seven deadly sins of CAAD, analyses the seven deadly sins of BIM, after critically reflecting on the uptake of computational design in practise. These are techno-centricity, where technology focus takes precedence over design process and culture, ambiguity of what the BIM spectrum might mean, elision of the information and responsibility of agents for it, hypocrisy of requiring IPD-Integrated Project Delivery as a silent twin project organisation to BIM, the delusion of asking for 2d information while requiring 3d work, diffidence - i.e. denying the need for process change where BIM is presented as an already good fit and monodisciplinary, where design exploration and design validation happen in professional silos.

Need

Against this analysis the paper puts forward dBIM-decentralised BIM as a paragon of virtues that can counter-balance some of BIM’s seven deadly sins. Through decentralisation, we are thus targeting the fragmented nature of the AEC industry, while providing the infrastructure for creating and adopting new business innovation and design innovation models.

BACKGROUND

While BIM advertises a high level of integration of information, this is not the case in terms of processes. The fragmentation of the AEC industries, where integration is a new idea, is evident in the separation of processes in the industry from the brief setting

to post-occupancy evaluations. For example Koutamanis [2017] describes the potential for integration of briefs with BIM processes and by extension how client needs can be embedded into BIM processes. In terms of working against technological fragmentation, and towards decentralised solutions, the most efficient current solution lies with BIM on Cloud. [Afsari et al] discuss extensively the opportunities and constraints that BIM interoperability in cloud-based collaboration poses. They identify that there is a knowledge and practice gap in terms of alternative technologies that can assist Cloud-BIM interoperability solutions. In parallel BIM cloud-based solutions, as discussed by Afsari et al, are developed in silos by the respective vendors, leading to vendor lock-in. They also discuss data exchange via MVD-.ifc schemas through the “cloud” where the vendor infrastructure is presented as a Software as a Service (SaaS) and Platform as a Service (PaaS) model. The discussion on cloud interoperability confines then itself to the established internet protocols, of Https, FTP, SMTP. In terms of interoperability four metrics are established: degree of interoperability, autonomy (the level of each cloud platform can work on its own, with no connection to other cloud apps), the degree of privacy of information, and the verification complexity. For example, [Almutairi et al] analyse federated, loosely coupled, and ad hoc collaborations based on these four metrics, and within these metrics the constraints of data exchange of BIM between cloud platforms are established. The constraints are related to compatible APIs, a universal data exchange format, but also the nature of the export and import of data through the APIs rather than .ifc format. Practically this means the data exchanged between “clouds” does not take place via exporting and importing in .ifc but by making specific calls to the API of each application.

Within this complexity, Doyle and Senske [Doyle et al 2019] construct a discussion on authorship, co-authorship and metadata analysing the co-dependency of designer-authors and originality on the work of others, in a sociotechnical framework that

accounts software and hardware interdependencies, for the creation of a single drawing. This interdependency, and the discussion that all authorship in design is in truth always a co-authorship fits very well with the diffusion and collective ownership and editing of BIM amongst a wide range of stakeholders, from experts to users. In this aspect of downstream users of data, Ozel [2005] discusses the confluence of BIM in the design, construction and management of buildings. The disconnect that exists between various phases of the design -construction-management in the AEC industry at the level of data. This incentivises a coordinated approach that integrates business processes across multiple phases of the lifecycle of a building project, and significant costs savings by efficient and effective use of data. Within the same paper, the challenges to achieving a uniform building information modelling approach that can seamlessly integrate data are presented: intellectual property concerns, both at the level of software and the data themselves, organisational challenges that are connected to the scale and fragmented nature of the construction industry, an incentivised AEC community, consensus on the level of the building model and where present, global aspects of BIM. How is it then that even various “cloud” versions of BIM do not completely solve the problem of fragmentation, intellectual property and design authorship, and organisational challenges of AEC projects? Is the nature of the industry such that only through a well orchestrated approach to information processing in tandem with organisational structures, design authorship (with whatever liabilities that might ensue) that BIM truly show its virtues and advantages? Within this context of challenges, we have turned to the distributed ledgers and the Ethereum blockchain as a potential data infrastructure paradigm.

DECENTRALISATION

The Ethereum Blockchain

The Ethereum Blockchain (ETH) is a universal state machine, a distributed equivalent to a Turing machine, implemented over a decentralised network

of nodes, that have a mechanism of reaching consensus on their state. On the Ethereum Blockchain data is immutable, public, and the blockchain itself embeds the capability to run codes in the form of “smart contracts” providing anyone with the opportunity to use Ethereum as a computer. As Ethereum is Turing complete, ie. it does not know when a computation will halt, the concept of “Gas” is introduced as a unit to measure the computational effort to run a specific operation, and create incentives for keeping computational loads low. Additionally, as per Turing completeness “Gas” ensures computations terminate. A further incentive to operate on the Ethereum platform is by “mining” ETH, the currency on which the platform itself is based, and getting rewarded for actively verify computational transactions by receiving ETH. As any other operation, storing data in the ETH blockchain has a cost and it is quite expensive due to the fact that it provides valuable services like immutability and distribution in the entire platform. Furthermore, the cost increases for larger set of data, hence forcing operators to look for alternative solutions for data storage. Some have used cloud storage such as Google Drive, Amazon Web Services or Autodesk BIM360, building within them their own Common Document Environment for BIM usage. However, in order to keep the consistency of the decentralised infrastructure concept and overcome the analysed problems with centralised servers, we opted for combining the Interplanetary File System IPFS in tandem with the ETH blockchain. IPFS is a distributed file system that allows the sharing of files on the web without the existence of a centralised infrastructure. Again, a network of nodes participates in IPFS by sharing storage space from their computational resources, where files are copied in a redundant manner.

Discussion of prior work and state of the art Methodology

Previous work by the authors [Dounas et al] have described levels of CAD integration, blockchains for optimising architectural design but also decen-

tralised autonomous organisations for architectural design, and new forms of structuring a design teams' decision-making approach[xxxx]. Our work with BIM has been unique in the sense that [Li et al] has recognised by surveying experts and building a socio-technical framework: the integration of BIM and blockchain has so far low engagement from researchers or practitioners. Other uses of the Blockchain in the AEC space include the financial incentivisation of tier 1 contractors [Kifokeris 2019], the management of supply chains [Qian et al, Kifokeris], the management of documents [Luo et al], the automation of billing and payments [Li et al, Ye et al], the automation of contracts between stakeholders and contractors [Di Giuda et al]. In particular, [Luo et al] mention the issue of using the blockchain as a means to verify the authenticity of a file and its authors. Within current cloud infrastructures they report the contradiction of storing the file in a centrally located and controlled server in a cloud infrastructure, while file verification and validation takes place on a decentralised distributed blockchain. As such, ideally the completely decentralised BIM solution involves the use of a DLT and the in tandem use of decentralised storage, computation capacity and memory. The Ethereum Blockchain presents itself as a particular platform where anyone can perform computations on, and as such one could run theoretically CAAD and BIM application directly on it. However the ETH platform is expensive in terms of storage and memory, due to the replication that takes place amongst its nodes. Hence there exists the need to decentralise the underlying infrastructure (Figure 1).

Value in BIM collaborations

The main goal of these strategies in collaboration in BIM is to safeguard and enhance value produced by the designers. Value then is not only added by identifying and resolving bottlenecks but is also produced in BIM by design collaboration. It would be a positive factor if we are able then to identify the pattern of creating value in design and the person(s) who created the value in a collaboration both as a responsibility

and as an action. Additionally, it would enhance our understanding of BIM collaborations if we are able to identify the moment at which value is created in a collaboration, but also which part of the project in which it was created. We should then be able to identify value creation in architectural design by identifying three key aspects: the pattern of adding value, the member(s) of the design team responsible and the chronology of value creation along with the subpart of the project where this takes place. At the opposite end of value creation, [Hattabe et al] identify the pattern of error creation along with the potential benefits of lean management practice in BIM processes, which are the reduction of errors and constraining their diffusion in the team. Value proposition of tool interoperability in BIM is more widely examined by [Grilo et al], where they conclude that value creation is not just tool specific in BIM but includes culture, context, values and business practices. Grilo et al furthermore develop the idea that contractual issues in BIM interoperability and all the aforementioned issues are only partly addressed by current BIM practices, and only in homogeneous BIM environments.

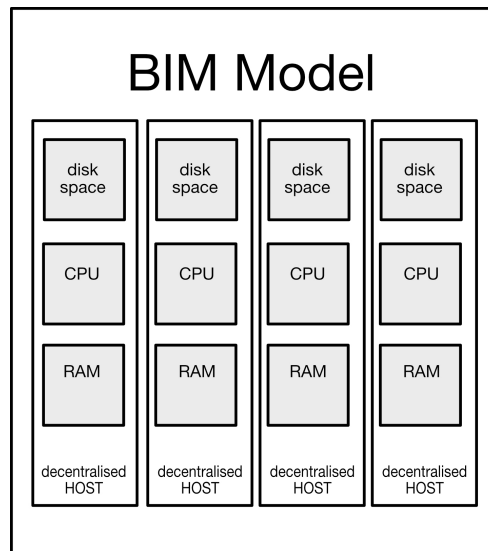

Figure 1
a completely decentralised BIM infrastructure: hosts share their CPU, RAM, Disk storage

We have employed a hybrid research method, combining an evolutionary prototype built-in software, which validates concepts in computational design. The hybridity of the method stems from using qualitative research within previous examples in literature and in parallel developing the smart contracts needed for our approach to work, and testing them in a semi-automatic manner. By using a public blockchain, the code and data used are already public on the Ropsten test network, hence accessible to other researchers to test. In relation to alternative processes, as with cloud storage, IPFS and the Ethereum blockchain work in our prototype in the same fashion as calls to a cloud API, hence the exchange of .ifc files is not needed. The advantage of course is that the computational control lies with the owners of the hardware and the IPFS space, rather than the operational administrator of a cloud infrastructure. By using IPFS and creating the smart contract on a test network one is able to validate the functionality of the prototype directly, and use this a minimum viable product to develop further decentralisation.

Smart Contracts

We implement two smart contracts, one that takes care of storing the IPFS hash value, and increasing the version number of the file, hence it stores two values, an integer and a hash.

Code :

```
pragma solidity ^0.6.0;
contract dbim {
//this is a string variable holding
↳ the IPFS hash of the file in
↳ question
string public difference = "
↳ I_pretend_to_be_an_IPFS_hash";

//unsigned integer- this is stand for
↳ the version of the file
uint public myUint;

function setMyUint(uint _myUint)
↳ public {
```

```
    myUint = _myUint;
}

function setIPFSHash(string memory
↳ _difference) public{
difference = _difference;
}
}

Code End/
```

The contract is deployed on the Ethereum test network "Ropsten" using the following transaction, with the following address. To access the contract one needs to either host a node on the "Ropsten" network or access it through a third party such as the MetaMask plugin on the chrome web browser. When deployed on the "Ropsten" test network one is able to set the IPFS hash of the file they are working on, and the version number (Figure 2).

```
https://ropsten.etherscan.io/address/
0
↳ xa008fa38996dce6e2671d77a66ec0f6f01a8ec1
↳
0xAAA08fa38996DcE6E26
71d77a66Ec0F6F01A8eC1
```

In parallel, an .ifc file is uploaded to IPFS, it is hashed, providing it with a unique identity, and shared with all stakeholders (Figure 3). The hash of the file from IPFS is used to uniquely identify that particular instance of the file, and is stored on the smart contract, increasing the version number by one. Thus one is able to keep track of the changes to the file, verify any kind of changes by comparing the hash files of the files on IPFS with the hashes that are stored in the contract in the blockchain. To save resources in case of frequent changes a third file with the record of all hashes can also be kept on IPFS and verified via a hash on the blockchain. This allows us to essentially create a decentralised BIM environment, where files are not stored on a cloud, but on a decentralised filesystem. Thus a design team can use IPFS storage for storing all their BIM files, edit them, and record the

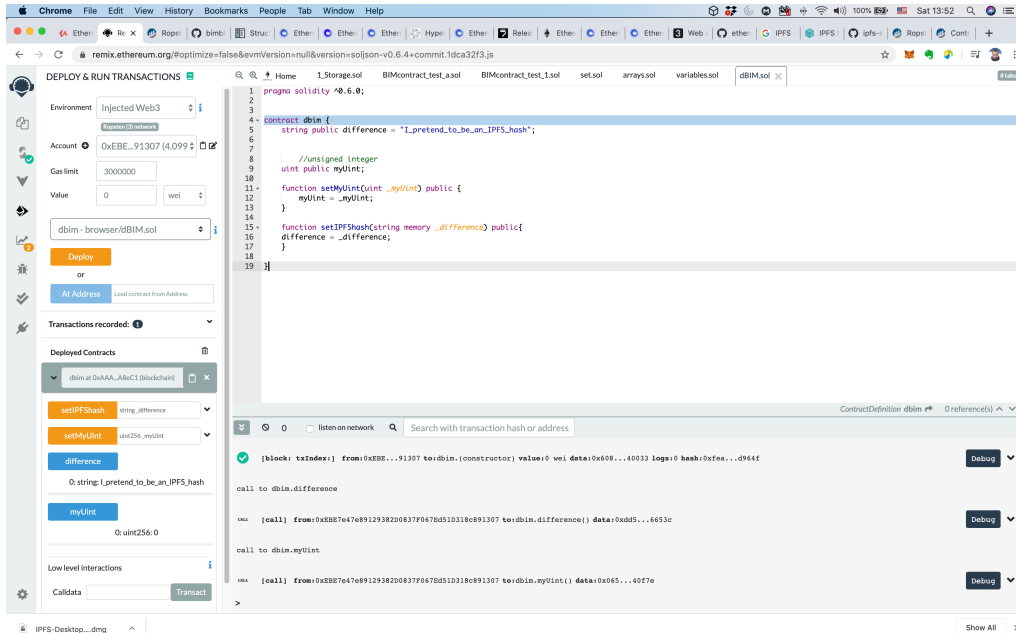

Figure 2
the smart contract that keeps track of BIM file changes, deployed on the “Ropsten” network. (by the authors)

hashes of the changes on a particular contract on the blockchain that is publicly verifiable. This negates the need for a centrally procured server in the cloud, but also cancels any kind of control that software vendors might have on the files of the users, a limitation that was recognised by Afsari et al [2017]

However a limitation exists in the number and incentives of IPFS nodes that would be willing to participate and clone the files on the IPFS common document environment that the design team creates by effectively storing files on IPFS. Thus we need to introduce incentives in the form of payments to these nodes. A complete diagram of the process is presented on Figure 4.

A similar smart contract handles the transaction for the decentralised hosts. It takes care of recording the hash values of the files stored, the time they are stored and edited, the size of the memory needed on each host for such decentralisation, and the amount

of ETH paid according to the incentives formula for the platform. To be able to protect intellectual property, files can be uploaded on IPFS after they have been cryptographically secured. This might take two forms, either digitally sign them, or completely encrypt them so that the IPFS nodes can not read the files. At the same time, BIM files on IPFS with their hashes stored on the blockchain can be verified by non-expert stakeholders.

This process creates two new business models for stakeholders in BIM: the model of the hosts, i.e computational nodes that act as the infrastructure of the model and get compensated for it by the users, and the architects who can exploit their intellectual property by sharing it on such a system with the world. A particular example are BIM parametric libraries. If an architect currently releases a parametric library on the web without any protection or encryption, anyone can exploit it without difficulty. With

Figure 3
BIM file loaded on
IPFS and hashed.

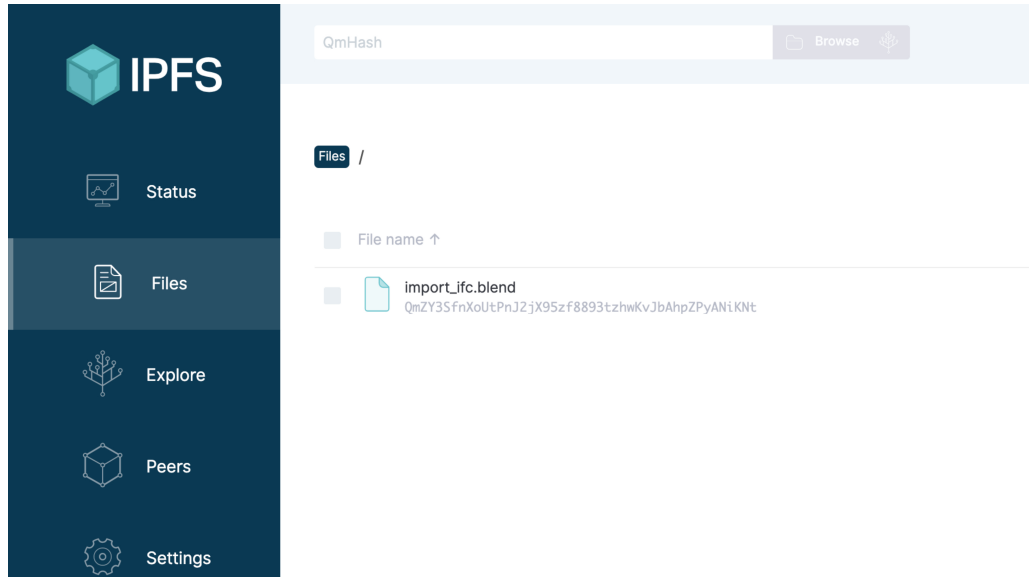
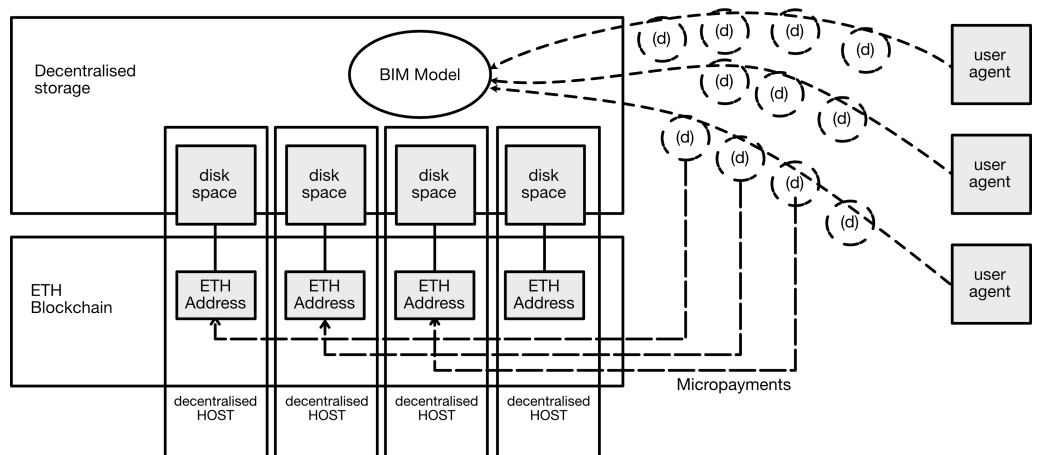

Figure 4
Diagram of
decentralised
storage and editing
operations for BIM.
(by the authors)



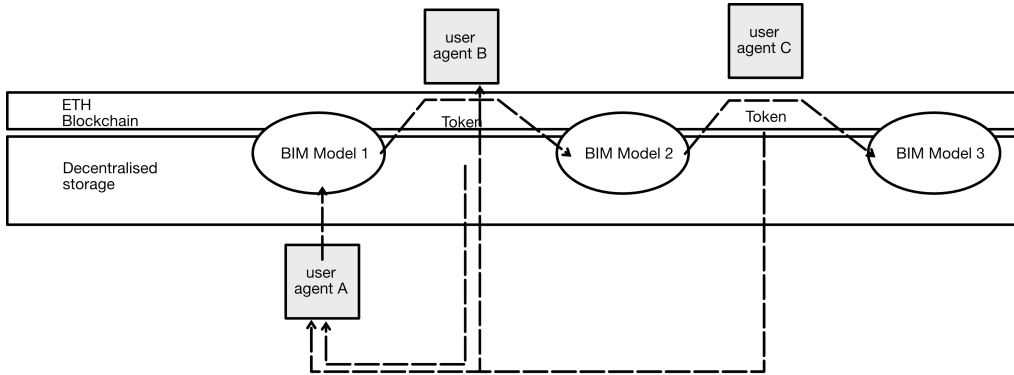

Figure 5
Incentivisation and tokenisation of BIM editing. User A creates the initial BIM file, gets assigned an initial token. User B edits and adds value, triggering a token payment for user A, while user C edits and adds value, triggering a token payment to both user B and user A as precedent co-authors. All transactions, user identities, tokens and value created are saved in the ETH blockchain.

using the facilities of the ETH blockchain and IPFS one can host whole files and libraries on the decentralised web, allow the use and modification of such a library and ensure payment through the execution of smart contracts. Taking this concept further one is able to also create additional work on top of these libraries by editing them and reusing them in another project. As such a BIM library or file stored on IPFS will have a series of authors, all recorded in an immutable manner, and a series of connection to projects, also recorded in an immutable manner. This immutability allows the secure execution of smart contracts to allow payment to each of the creators and co-authors of each library. The difficulty and constraint there in lies in the form and ratio of the payment according to the actions and the value that each contributor to the library has created. At the computational level, we can overcome the attribution to Fiat Currencies by using tokens on the ETH blockchain, where each contributor accumulates tokens for each edit and use that takes place down the line on the library they created. (Figure 5)

This tokenisation of design action can lead to the creation of an internal economy within the decentralised Building Information Modelling application, where each user-agent and stakeholder is incentivised to maximise value for the whole ecosystem and the increase of the collective value will also

increase each user's compensation. As an organisational model this shadows the processes of Integrated Project Delivery model, but provides the infrastructure, scope and scale for a decentralised and wide, global application.

Discussion

The simple infrastructure we have developed poses a number of questions in terms of organisational infrastructures, ownership of this infrastructure, along with the desired balance of control versus value in the architectural design practice. In terms of production and control of information, we understand that industry 4.0 poses a number of challenges to architectural design under the lens of automation. Others [Koenig] have compared Industry 4.0 processes and their automation with Cybersyn, the control infrastructure developed by the socialist government in Chile, in 1973, taking into account the embedding of information nodes directly into production. In parallel what we are proposing the embedding of value much closer to the architectural production, but also the explicit recognition of value creation through architectural design. The challenge lies of course in being able to establish and compare qualitative value in each edit of the files in an architectural design paradigm: Are all edits of a BIM file creating value? Are there specific patterns that we

can observe if we diligently record the blockchain a series of authors that edit the file in turn? Can we observe and classify such patterns and recreate them in the future? Certainly the infrastructure proposed here allows for such embedding and for such a control to be recorded. We would need a certain scale though, perhaps globally, to be able to recognise patterns of value creation. We mention a global scale, as the ambition is to have the infrastructure described here used by as many architects as possible, administered as a commons, rather than as just another tool.

CONCLUSIONS

We have presented a set of scripts that create a proof-of-concept in creating the nucleus of decentralised building information modelling. Our prototype allows for the participation and collaboration of a decentralised design team, the creation of a shared infrastructure for common document environments, and the incentivisation of stakeholders that participate in the creation of this decentralised infrastructure. Within this infrastructure, one is also able to foresee new business models for architects and computational designers, where for example designers publish a computational design file or a BIM family/parametric assembly on IPFS, verify their authorship through the blockchain, for example a particular computational design that is valuable to others. Then other architects and computational designers take that file and edit, or use it and incorporate it into their own work, paying through the blockchain at the same time the original creator, but also any other computational designer that has edited the file. Through the blockchain we will be able to build an architecture of collective authorship, where architects are incentivised to participate and share their work because they will get rewarded. We look forward to building the software infrastructure that will make this possible.

REFERENCES

- Afsari, K, Eastman, C and Shelden, D 2017, 'Building Information Modelling data interoperability for Cloud-Based collaboration: Limitations and opportunities', *International Journal of Architectural Computing*, 15, p. 187–202
- Almutairi, A, Sarfraz, M and Basalamah, S 2012, 'A distributed access control architecture for cloud computing', *IEEE Software*, 29, pp. 36–44
- Dounas, T, Lombardi, D and Jabi, W 2019 'Towards Blockchains for architectural design - Consensus mechanisms for collaboration in BIM', *Proceedings of eCAADe / siGRADi 2019*, Porto, pp. 267–274
- Doyle, S and Senske, N 2018, 'Digital provenance and material metadata: Attribution and co-authorship in the age of artificial intelligence', *International Journal of Architectural Computing*, 16, p. 271–280
- Ferrari, G.T 2017, 'Design and the fourth industrial revolution, dangers and opportunities for a mutating discipline', *The Design Journal*, 20:sup1, pp. S2625–S2633
- Di Giuda, M.G, Pattini, G, Seghezzi, E, Schievano, M and Paleari, F 2020, 'The Construction Contract Execution Through the Integration of Blockchain Technology, chapter', in Danniotti, B, Gianinetta, M and Della Torre, S (eds) 2020, *Digital Transformation of the Design, Construction and Management Processes of the Built Environment*, Springer Open, Milan, Italy
- Grilo, A and Jardim-Goncalves, R 2010, 'Value proposition on interoperability of BIM and collaborative working environments', *Automation in Construction*, 19(5), pp. 522–530
- Hattab, MA and Hamze, F 2018, 'Simulating the dynamics of social agents and information flows in BIM-based design', *Automation in Construction*, 92, pp. 1–22
- Holzer, D 2011, 'BIM's seven deadly sins', *International journal of Architectural Computing*, 9, pp. 463–479
- Kifokeris, D and Koch, C 2019 'Blockchain in building logistics: emerging knowledge, and related actors in Sweden', *Proceedings of the 35th Annual ARCOM Conference*, Leeds, UK, pp. 426–435
- Koering, D 2019 'What We Should Have Learned From Cybersyn', *Proceedings of eCAADe / siGRADi 2019*, Porto
- Koutamanis, A 2004, 'CAAD', *International Journal of Architectural Computing*, 29, p. -
- Koutamanis, A 2017, 'Briefing and Building Information Modelling: Potential for Integration', *International journal of Architectural Computing*, 15, p. 119–133

- Li, J, Greenwood, D and Kassem, M 2019, "Blockchain in the built environment and construction industry: A systematic review, conceptual models and practical use cases", *Automation in Construction*, 102, pp. 288-307
- Luo, H, Das, M, Wang, J and Cheng, J.C.P 2019 'Construction payment automation through smart contract-based blockchain framework', *36th international symposium on Automation and Robotics in Construction (ISARC 2019)*
- Maver, T 1995 'CAAD's seven deadly sins', *Sixth International Conference on Computer-Aided Architectural Design Futures*, Singapore, pp. pp. 21-22
- Ozel, F 2005, 'Confluence of Building Information for Design, Construction and Management of Buildings', *International Journal of Architectural Computing*, 03, pp. 373-390
- Qian, X and Papadonikolaki, E 2019 'The Influence of the Blockchain Technology on Trust in construction Supply Chain Management', *2019 CIB International Council for Research and Innovation in Building and Construction Conference*